

SOUTHWEST ASSOCIATION OF TURNERS

28TH

ANNUAL SYMPOSIUM

2019 Demonstration Handbook



TABLE OF CONTENTS

Welcome	3
Event Schedule.....	4
2019 SWAT Vendors	5
Symposium Floor Plan.....	6
Friday Rotation.....	7
Saturday Rotation	8
Sunday Rotation.....	9
Family Programs	10
Women in Turning	10
Turners-to-Go	10
Beads of Courage	11
Executive Committee Members	12
Supporting Chapters	15
List of Demonstrations.....	16
Creating a Skill Set	17
Blending Embellishments	21
Hand Chasing Threads, The Castle Box	24
A Sea Urchin Box	27
Avisera Blocks and Inlays.....	30
Wood Turning Puzzle & Square Bowl.....	32
Adding Gilder’s Paste to Your Burned and Carved Patterns	34
Complete the Illusion with Color Using Milk Paint and/or Gesso.....	36
Angel Ornament	38
Casting and Finishing.....	43
Turning Corian	48
Segmenting, Beyond Basics.....	54
Texturing and Coloring an Offset Bowl	57
Walking Bowl.....	61
Tips & Tricks for Perfection in Pens.....	68
Taking Pen Presentation to the Next Level.....	71
Embellishing with Milliput.....	74
Making Your Own Natural Void	75
Are You With Me?	76
Sunburst Bowl	78
Skew Chisel.....	85
A Vortex Bowl.....	88
Inlay Kit Assembly	96
Sandblasting	101
Three and Six Pointed Winged Vessels	105
Turning a Burl Cap	109
Making Pen Blanks from Bottle Caps	113

Getting Started with Segmenting.....	115
Compound Miters and Ribbons	115
Tubal Segmented Constructions	115
Shades of Tiffany	121
Mini Hollow Forms	125
About the Artists.....	133
Southwest Association of Turners (SWAT) History.....	144

WELCOME

to the

SOUTHWEST ASSOCIATION OF TURNERS SYMPOSIUM

This is the 28th Anniversary of Southwest Association of Turners. On behalf of the Board of Directors from each of our 28 member clubs, the Executive Committee, the Committee Chairs and all of the many volunteers who work to make this the best Woodturning Symposium in existence, I would like to thank you for your support of the SWAT Symposium for the past 28 years. We expect this will be a great learning experience to all attending.

There are 54 vendors who offer tools and accessories, lathes and lathe accessories, woods of all species, finishing, dyeing and enhancement items, sanding materials, new tools and turning items, stabilizing equipment, etc. Once you have purchased that new tool, you can go to the Hands On or Pen Turning Booth and try out the new tool(s).

Our famous and ever popular **Two-for-One drawing is now Three-for-One!** The first opportunity to win something is at the opening ceremony on Friday morning. The winner will receive a Jet midi lathe or an Arrowmont scholarship. The second drawing is at the banquet Saturday evening. This opportunity will include approximately 30 pieces of gorgeous art. All tickets drawn Friday and Saturday are returned to the bin earning the "Three-for-One" name. The third and final drawing will be held on Sunday at lunch. This raffle will be for tools, wood, turning accessories donated from our vendors, a scholarship to Arrowmont and LATHES! **New this year, a number of art pieces will be auctioned** Saturday night, at the banquet, - complete with a professional auctioneer (for added excitement and fun). The expectation is to have around 15 pieces of art to sell to the highest bidder.

Our Art Gallery is second to none. It is the largest of its kind in the U.S.A. and is such a special area that we dedicate an entire room for art pieces that are displayed by turners that are attending the Symposium. Any turner has the availability to display (some are for sale) up to ten items in our ART GALLERY. Also, a section in the Art Gallery will be dedicated to the Beads of Courage exhibit of boxes that will be donated to various hospitals to be given to youngsters that are struggling through various treatments for serious life threatening diseases. You can check the SWAT website for more information and a link to the Beads of Courage website.

For a nominal registration fee of \$140 you will be exposed to 7 internationally known Lead Demonstrators and 17 Regional demonstrators, which create 63 turning rotations. You will receive an electronically generated handbook, access to a tremendous Art Gallery, a conversation with Sally Ault, Andy Chen and Malcom Tibbetts on Friday night, various vendors and three separate drawings for art and tool items. Women in Turning will gather during lunch on Friday, and World of Woodturning (WOW) meets after lunch on Saturday.

None of the above would be possible without your participation and the efforts of many volunteers that work hard and long to bring the SWAT Symposium to you each year. **So, welcome and may you have an outstanding experience at the 28th Anniversary of the SouthWest Association of Turners Symposium.**

Gordon Graves
President, SouthWest Association of Turners

EVENT SCHEDULE

Thursday	7:00 AM	Doors Open for Vendors (Tables Not Available Until Unloading Complete) Registration Set-up (Staff Only)
	11:30 AM	Lunch for Vendors
	12:00 PM	Lunch
	3:00 PM	Registration & Logo Ware Sales Open (Drawing Ticket Sales @ Window #4)
	3:00 – 6:00 PM	Gallery Open for Check-in
	5:30 PM	Vendor Unloading Closes
	6:00 PM	Registration & Logo Ware Sales Close
	Friday	7:30 AM
8:00 AM		Registration & Sales Open
9:00 AM		Opening Ceremonies in Chisholm Hall First 3-for-1 Drawing (Jet Lathe and Arrowmont Scholarship)
10:30 AM		Demonstration Rotations Begin
11:30 AM		Lunch for Vendors
12:00 PM		Lunch
5:00 PM		Gallery Closes
5:30 – 8:00 PM		Cash Bar
6:00 – 7:30 PM	Friday Fish Fry Dinner Note: Tickets must be purchased in Advance	
7:30 – 9:00 PM	A Conversation with Andy Chen, Sally Ault and Malcolm Tibbetts (See Rotation Schedule)	
Saturday	7:00 AM	Registration Opens
	7:30 AM	Gallery Opens
	8:00 AM	Demonstration Rotations Begin
	11:30 AM	Lunch for Vendors
	12:00 PM	Lunch
	5:00 PM	Gallery Closes
	6:00 – 8:00 PM	Cash Bar
	6:30 – 7:30 PM	Banquet Dinner
7:30 – 9:00 PM	Second 3-for-1 Drawing	
Sunday	7:30 AM	Gallery Opens
	8:00 AM	Demonstration Rotations Begin
	11:00 AM	Gallery Closes for Disassembly (Artist Pick-up Turnings)
	12:00 PM	Demonstration Rotations End Lunch Third 3-for-1 Drawing (Tool and Lathe Drawing) Vendors can begin Teardown of Booths

2019 SWAT VENDORS

- 2 Tree Boyz Wood — 2treeboyz@gmail.com
 Accu-Slice — info@accu-slice.com
 Airbrushing Wood — jtfleming@san.rr.com
 Alan Lacer Woodturning — alan@alanlacer.com
 Amalgam-Mutt Blanks — esoto70431@hotmail.com
 American Association of Woodturners —
linda@woodturner.org
 Australian Burls — AustralianBurls.com
 AZ Carbide — campbelnye@gmail.com
 Big Monk Lumber — pete@bigmonklumber.com
 Bigfoot Carving Tools dba The Old Texas
 Woodcarvers Shop —
sales@bigfootcarvingtools.com
 Carter and Son Toolworks —
contact@carterandsontoolworks.com
 Century Tree Turnings —
mikescustommill@hotmail.com
 Cindy Drozda Woodturning Tools —
cindy@cindydrozda.com
 Conestoga Works — charles@conestogaworks.com
 Custom Fixtures by Pete Marken —
p_marken@bellsouth.net
 Easy Inlay — nnapurski@lionheartpr.com
 Flute Master — dick@webbock.com
 Frugal Vacuum Chuck —
FrugalVacuumChuck@gmail.com
 Heritage Wood School —
mark@homesteadheritagefurniture.com
 Hill Country Woods — james@hcwtexas.com
 Hunter Tool Company — MLH55410@aol.com
 James Kesler — james.kessler@att.net
 JT Turning Tools — tom@jtturningtools.com
 Kallenshaan Woods — kallenshaan@cox.net
 Live Edge Mesquite — jeffbob@verision.com
 Lyle Jamieson Woodturning —
lyle@lylejamieson.com
 Mike Alan Designs —
mikealandesigns318@gmail.com
 Nave's Sawmill & Woodworks —
wendy@mesquiteTREE.org
 Oneway Manufacturing — kevin@oneway.ca
 Ornament Buttons — g3en@yahoo.com
 PTownSubbie — PTownSubbie@gmail.com
 Ring Master — pmerritt@capefearautomation.com
 Rising3B Woodworks — rising3b@rising3b.com
 Robust Tools — brent@turnrobust.com
 Rotary Chisel — rotarychisel@gmail.com
 Specialty Lumber & Logging —
woodchipper2011@hotmail.com
 Spiracraft — accounts@spiracraft.com
 SS Niles Bottle Stoppers — ruthniles@gmail.com
 Stainless Bottle Stoppers —
sales@stainlessbottlestoppers.com
 Stones Custom Pens — www.stonespenblanks.com
 The Classic Nib — theclassicnib@hotmail.com
 Thompson Lathe Tools —
doug@thompsonlathetools.com
 Tradesman Grinder — cuttermaster@gmail.com
 Turners Warehouse — chadschimmel@gmail.com
 TURNINGWOOD.COM — steve@turningwood.com
 TurnTex — Curtis@turntex.com
 Vince's Wood N' Wonders —
vince@vinceswoodnwonders.com
 Wood Turners Wonders —
kjrdistributing@gmail.com
 Wood World of Texas — woodworldtx@gmail.com
 Woodturner PRO — lloyd@woodturnerpro.com
 Woodturners Workholding Solutions —
gmwoodworking78@msn.com
 Woodturning Tool Store —
tod@woodturningtoolstore.com
 Woodturning with Tim — info@wtwtim.com
 Woodworker's Emporium — chbww@gmail.com

Support SWAT Vendors

Many come from halfway across the country to
 bring you their products. Show them our
 Southwest Hospitality

WACO CONVENTION CENTER

Upper Level

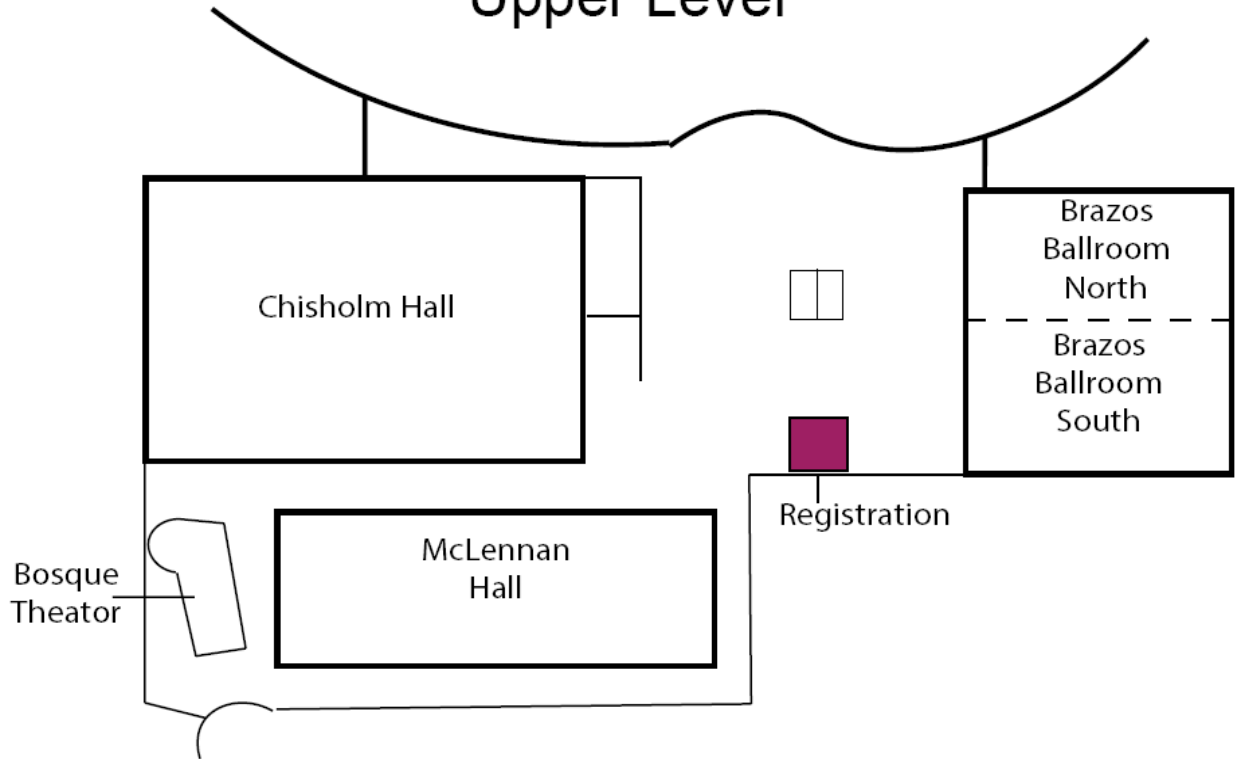

Lower Level

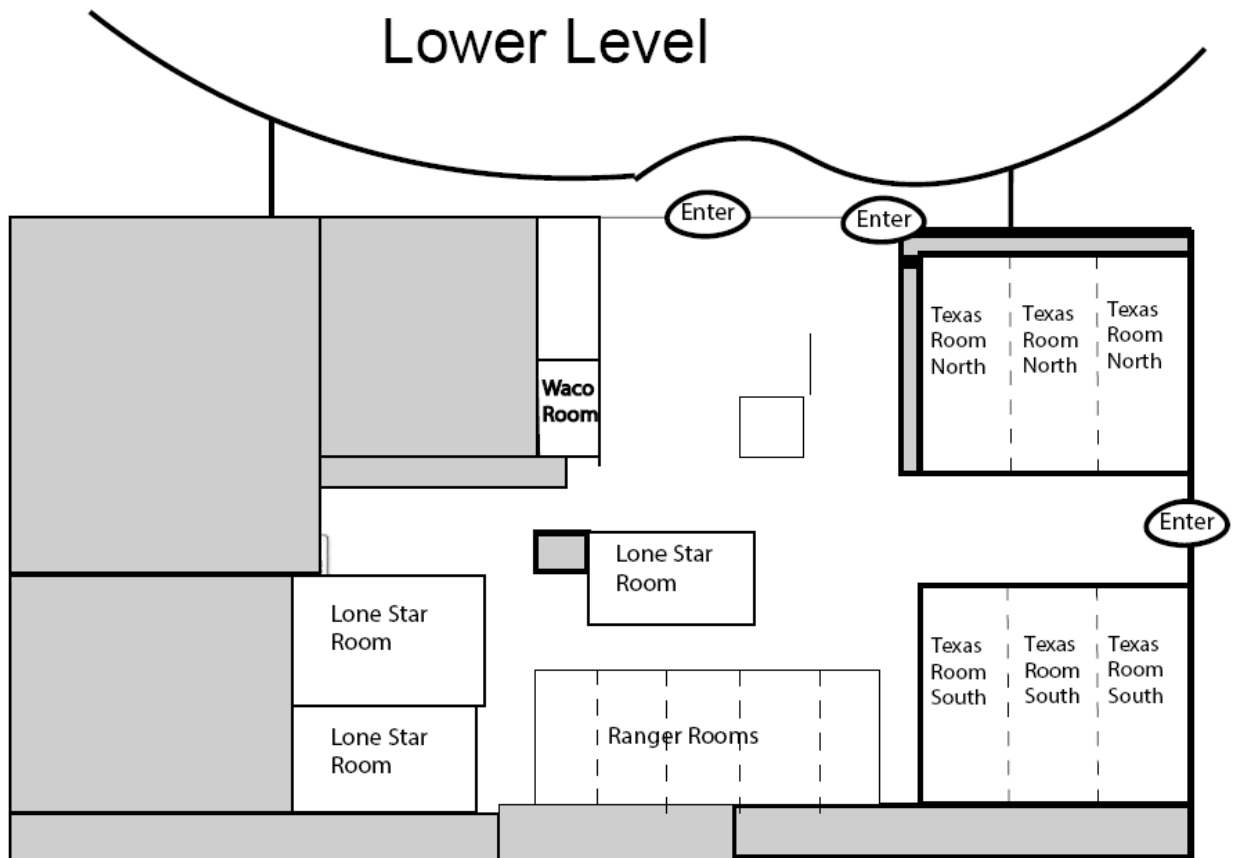

2019 ROTATION SCHEDULE

ROOM	BRAZOS NORTH ROBUST	BRAZOS SOUTH POWERMATIC	TEXAS NORTH POWERMATIC	TEXAS SOUTH 116/117 JET	TEXAS SOUTH 118 POWERMATIC	RANGER POWERMATIC	BOSQUE THEATRE JET
SPONSOR	HUNT COUNTY	WNT	CTWA	GCWA	HILL COUNTY	DAW	APT
FRIDAY - August 23, 2019							
9:00-10:00	Opening Ceremonies - Chisholm Hall- 3 FOR 1 RAFFLE						
10:30 - 12:00	MALCOLM TIBBETTS Getting Started with Segmenting	ELI AVISERA Avisera Blocks and Inlays	BUDDY COMPTON Texturing and Coloring an Offset Bowl	DONNA BANFIELD Patterns, Textures and Color 1	LARRY ZARRA Mini Hollow Forms	SAM ANGELO Blending Embellishments	JIM SWANK Making Pen Blanks from Bottle Caps
12:00 - 1:30	LUNCH Women In Turning - Brazos North						
1:30 - 3:00	LARRY RANDOLPH Sandblasting	SALLY AULT A Sea Urchin Box	ANDY CHEN Turning Corian	ALAN LACER Skew Chisel	CARL JACOBSON Embellishing with Miliput	KEVIN BASSETT Angel Ornament	KURT HERTZOG Tips & Tricks for Perfection in Pens
3:00 - 4:00	Break						
4:00 - 5:30	MALCOLM TIBBETTS Compound Miters and Ribbons	ELI AVISERA Wood Turning Puzzle & Square Bowl	BARRY TODD Shades of Tiffany	DONNA BANFIELD Patterns, Textures and Color 2	LYLE JAMIESON Are You With Me?	ROY ALVAREZ Creating a Skill Set	KEN NELSEN Inlay Kit Assembly
6:00 - 7:30	Special FISH FRY Dinner - Chisholm Hall						
7:30 - 9:00	A Conversation with Andy Chen, Sally Ault, and Malcolm Tibbetts						

Saturday - August 24, 2019

ROOM	BRAZOS NORTH ROBUST	BRAZOS SOUTH POWERMATIC	TEXAS NORTH POWERMATIC	TEXAS SOUTH 116/117 JET	TEXAS SOUTH 118 POWERMATIC	RANGER POWERMATIC	BOSQUE THEATRE JET
8:00 - 9:30	MALCOLM TIBBETTS Tubal Segmented Constructions	MARTY KAMINSKY Sunburst Bowl	REBECCA DEGROOT Walking Bowl	BRIAN SCHRADER Three and Six Pointed Winged Vessels	CARL JACOBSON Making Your Own Natural Void	SAM ANGELO Hand Chasing Threads The Castle Box	BRIAN BLOHM Casting and Finishing
9:30 - 10:30	Break						
10:30 - 12:00	LARRY RANDOLPH Sandblasting	SALLY AULT A Sea Urchin Box	ANDY CHEN Segmenting, Beyond Basics	ALAN LACER Skew Chisel	LARRY ZARRA Mini Hollow Forms	KEVIN BASSETT Angel Ornament	KURT HERTZOG Taking Pen Presentation to the Next Level
12:00 - 1:30	1:00 - 1:30 World Of Woodturners (WOW) Gathering - Brazos South						
1:30 - 3:00	MALCOLM TIBBETTS Compound Miters and Ribbons	MARTY KAMINSKY Sunburst Bowl	JIM SWANK Making Pen Blanks from Bottle Caps	DONNA BANFIELD Patterns, Textures and Color 1	ROY ALVAREZ Creating a Skill Set	SAM ANGELO Blending Embellishments	KEN NELSEN Inlay Kit Assembly
3:00 - 4:00	Break SWAT Directors Board Meeting -WACO ROOM						
4:00 - 5:30	PETE MARKEN A Vortex Bowl	REBECCA DEGROOT Walking Bowl	ANDY CHEN Turning Corian	BUDDY COMPTON Texturing and Coloring an Offset Bowl	CARL JACOBSON Embellishing with Miliput	DREW SHELTON Turning a Burl Cap	KURT HERTZOG Tips & Tricks for Perfection in Pens
6:00 - 8:00	Cash Bar						
6:30 - 7:30	Banquet Dinner						
7:30 - 9:00	3 - For - 1 Drawing--ART AUCTION						

Sunday - August 25, 2019							
ROOM	BRAZOS NORTH ROBUST	BRAZOS SOUTH POWERMATIC	TEXAS NORTH POWERMATIC	TEXAS SOUTH 116/117 JET	TEXAS SOUTH 118 POWERMATIC	RANGER POWERMATIC	BOSQUE THEATRE JET
8:00 - 9:30	PETE MARKEN A Vortex Bowl	ELI AVISERA Wood Turning Puzzle & Square Bowl	ANDY CHEN Segmenting, Beyond Basics	DONNA BANFIELD Patterns, Textures and Color 2	LYLE JAMIESON Are You With Me?	SAM ANGELO Hand Chasing Threads The Castle Box	KURT HERTZOG Taking Pen Presentation to the Next Level
9:30 - 10:30	Break						
10:30 - 12:00	MALCOLM TIBBETTS Tubal Segmented Constructions	ELI AVISERA Avisera Blocks and Inlays	BARRY TODD Shades of Tiffany	BRIAN SCHRADER Three and Six Pointed Winged Vessels	CARL JACOBSON Making Your Own Natural Void	DREW SHELTON Turning a Burl Cap	BRIAN BLOHM Casting and Finishing
12:00 - 1:30	Lunch and Tool Drawings						
<p><i>Note: Schedule subject to change as needed. Changes will be posted to the website as soon as they are available!</i></p> <p>Travel Safe & Have a Safe and Productive Turning year...</p>							

FAMILY PROGRAMS

Whether you are a woodturner or not, there are plenty of things to do aside from watching shavings fly. The list of classes that family members can take grows each year. Some of the classes in past years include crochet (a lovely scarf), fusing glass (for jewelry), and paper crafting (handmade cards).

The content of the classes varies from year to year - and they just keep getting better.

There are multiple classes available throughout the day and some of them include field trips in Waco (quilt shop). Each day provides a myriad of opportunities to learn something new. You are even likely to leave with a few new craft pieces. You will certainly leave with new friends.

Every member of the family is welcome at SWAT. Younger family members can even learn to turn a pen from seasoned woodturners.

WOMEN IN TURNING

The Southwest Association of Turners Symposium 2015 hosted its first **Women in Turning** gathering. **Women in Turning** is a virtual chapter of the American Association of Woodturners, that had its start at the 2014 AAW Symposium in Phoenix, AZ when Betty Scarpino organized a meeting of women to see if there was interest in forming a group focused on the support of women woodturners.

There was definitely enough interest. If you are attending the SWAT Symposium this year, please plan to join our meeting. The time and place will be posted throughout the Convention Center and on the Rotation Schedule. Check out the group at: [AAW Women in Turning](#)

TURNERS-TO-GO

Southwest Association of Turners is pleased to announce a new program that we are sure will be a great benefit to our member organizations—Turners to Go. This page on our website will list the names of outstanding regional turners who would like to visit your club and demonstrate and/or teach hands-on classes.

If you are interested in being one of our visiting demonstrators, please fill out the application form and forward it to Chairman Janice Levi at jlevi@rightturnonly.net. A committee will check the application for completeness before posting it on the website.



Member organizations are invited to search the page by demonstrator name or by subject (hollowing, natural edge bowls, ornaments, etc.). References will be provided by the applicant. Demonstrator fees will not be set by SWAT but will be negotiable between the club and the turner. We hope that demonstrators and our member organizations will find this new program helpful in locating and securing qualified turners for club meetings and classes.

Are you interested? Click on the link to be taken to an application form ([Turners to Go Application](#)). Your application will be reviewed by a committee before posting to the website. Thank you! We hope you find this program helpful.

BEADS OF COURAGE

The SWAT Symposium took on the Beads of Courage program in 2010. SWAT's involvement was inspired by Craig Fyock, owner of Wood World, Texas. Each year the contributions for the Beads of Courage program exceeds the previous year. SWAT attendees and support of our vendors has made this possible. There were 149 boxes made in 2014. If you are not familiar with the program, visit the Beads of Courage web site www.beadsofcourage.org, it is really a heart-warming experience. If you want specific information regarding participation as a woodturner, or guidelines for making and donating your boxes go here: [Beads of Courage Guidelines](#). If you plan to display any of your Beads of Courage "boxes", please complete the online form ([Beads of Courage Registration form for SWAT 2019](#)). It would be a very good idea to print it and bring a copy with you to SWAT. Note: The Beads-of-Courage entries will not be judged this year. A few images from 2018 to inspire you:



EXECUTIVE COMMITTEE MEMBERS

PRESIDENT, GORDON GRAVES

I was first introduced to a wood lathe in 1960, in 7th Grade wood Class. Mr. McDonald, my instructor, helped me attach a face plate to a chunk of maple. Took me three weeks of class to turn my Dad an ashtray. I still have that ashtray. After high school and college I started farming, forty-two years later I retired. During that 42 years I put together a good woodworking shop. Farming was always my first love, but woodworking came a close second. I bought my first lathe in 1992, a small Craftsman bowl lathe. In 2013 I decided I needed a bigger lathe, but during the hunt I found something much more valuable, The Southplains Woodturners Club. Mr. Glenn Williamson, one of the founding fathers of our club, sold me a lathe and sold me on the club. I joined the club shortly after and have attended many classes, beginners and intermediate. I am now helping to teach these same classes as well as serving as the club treasurer. I attended my first SWAT symposium in August of 2016 and was amazed at the number of people who were interested in woodturning. Everyone I met was friendly and helpful. I am looking forward to helping to carry on the proud tradition of SWAT.



1ST VICE PRESIDENT, HENRY PENNELL

My first experience with a lathe was at a Woodworking Show in Dallas in 2009. Craft Supplies had a booth and invited me to make a pen. I was hooked. Later, I took a class from John Horn at Woodcraft, and bought a Jet mini lathe. I joined Dallas Area Woodturners (DAW) in November of 2010, and the demonstrator was Michael Hosaluk. Wow, I was mesmerized by his skill and the ease with which he handled his tools. I later became Treasurer of DAW in 2013, and most recently, President in 2017. I attended my first SWAT Symposium in 2013, and have been here every year since. I love talking to the other turners, seeing the demos and expanding my awareness of the various areas of our craft. I hope to help SWAT prosper and improve in the coming years.



2ND VICE PRESIDENT, TOM BEATTY

My love of woodworking comes from my father and oldest brother who were carpenters and owned a cabinet shop in Virginia. At 3 years old, I received a tool box and have been woodworking ever since. My dad showed me how to turn bowls, lamps and table legs using an early 1950s era Shopsmith. Even though college, family life and engineering career took most of my time, I always had time for woodworking. In 2005, my lovely wife bought me a Jet mini lathe as a birthday present without knowing the future she was creating. I tried learning how to use my new lathe by reading books, watching videos and I making lots of shavings and turning lots of pens. In 2008, I met Larry Roberts, who introduced me to Woodturners of North Texas. Thanks to Larry and the club, I learned more in the next 6 months than I had working on my own for almost 3 years. After 4 years in the club, I was elected club Secretary, a job I held for 5 years. I started attending SWAT in 2012 and have attended every year since. I enjoy the



learning experience that SWAT offers from world class demonstrators and vendors demonstrating their products and showing capabilities of new tools and equipment. I look forward each year to meeting old and new friends and sharing turning experiences. I am honored to be given the opportunity to help SWAT continue to be the world's best woodturning symposium.

SECRETARY, BETTY HAGER

Woodturning is not my primary hobby, but being married to Stacey Hager; I have had some quality lessons and have turned several art objects. When I turned these I was using a Delta Midi lathe or Stacey's 2436 One Way. I have attended this woodturning symposium since it was called TTT (Texas Turn or Two) and was held at the Maricopa Camp Ground. I remember the first time we attended a TTT symposium. The Maricopa location offered a few motel rooms and plenty of camp sites. There was a large barn where two demonstrations were staged and two smaller buildings for the other two demos; four choices at each rotation. The vendors were in tents! There were two to three tables where turners could display their work called the "Instant Gallery!" These early get-togethers were held in October. When the weather was great it was a perfect time of year...but we had two cold rainy years in a row. Something had to change. So we tried other locations – San Angelo, Temple, Wichita Falls...finally finding our current venue at Waco. Stacey and I were representatives from our Club (Central Texas Woodturners) when we transitioned from TTT to Southwest Association of Turners (SWAT). In 2008, I served as secretary to Steven Gottlieb when he was President of SWAT. I wrote a manual for the organization to provide some continuity from one year to the next. I have attended AAW and the Utah Woodturning Symposium and they are both wonderful, but what impressed me early on about our gathering was the spirit of friendship and willingness to share. The name tags at TTT always had your first name in large type...for everyone, turners and presenters. So everyone was on a first name basis. I watched David Ellsworth shoot long streamers of wood from his hollowing project, targeting friends in the audience. Rude Osolnik, gave me my first tuning lesson in a tent at the Powermatic booth. We have come a long way from those days, but I believe in this organization. Whether you are a beginning turner or an advanced artist, you will meet some great people at this Symposium and every time you attend you will learn something that will improve your skills.



TREASURER, DAVE MARSHALL

Raised in a small cabin on the plains of Kansas, I started my woodworking and woodturning career early in life. After building my first, small lathe, I began my woodturning career by selling hand-turned toothpicks to local farmers and businessmen. My skill set grew tremendously during this period which culminated in my ability to use a scraper to turn almost any product on the lathe. When I was thirteen, I read with lust about turner David Ellsworth in in an old black and white edition of Fine Woodworking. That article vaulted me to turn (scrape) my first box and lid. A beauty of a specimen in black walnut. Form and function – perfect. The bottom lacking just somewhat as not being completely flat and bearing the hallmark of three screw holes that attached the faceplate. Still stunning today. Thirteen was the age a young student began his first year in Industrial Arts



class in junior high school. After sweet-talking my Industrial Arts teacher, Mr. Anderson, he allowed me to come to shop before classes started for the day and turn all I wanted. He showed me the very basics of some of the limited tools we had available for turning. For some reason I don't ever recall a lesson in sharpening these tools though... that probably explains my expertise with the scraper. I turned my heart out that year; sock darns, miniature baseball bats, candlesticks, miniature baseball bats, boxes, small plates, miniature baseball bats to name a few. Something happened. I think life, girls, schooling, college, my masterplan to escape Kansas tapered my turning time. Now don't get me wrong, I tried to design and woodturn as much as possible. I've always loved the design and then build and then re-design cycle of creation. Maybe that's why I became an Aerospace engineer. After graduation and landing in sunny Burbank, California, I got my first paycheck. I bought my first Shopsmith for my single-car garage/shop. I was on my way! Years later, and hundreds of projects later, we ending up in panther-sleepy Fort Worth. After starting a family, I began to look for a woodworking club to join, similar to ones I belonged to in California and Georgia. Not finding anything close by in the Metroplex, I ran across a magazine article featuring Devore Burc and its mentioning of a bunch of ragtags called the Woodturners of North Texas. Whoa... they met only three miles from my home! Their next meeting, I snuck in and grabbed a seat and was blown away by the demo. I was hooked again. I know that this is fascinating as all get-out, but long-story short, I joined that ragtag bunch and haven't looked back. After a while, I was president of the Woodturners of North Texas. The glamour and prestige went to my head and I ruled the Club with an iron fist for four years. That group of ragtags became a lean, mean turning machine, I say. As a Club member, I became familiar with the South West Association of Turners and attended my first SWAT symposium. Blown away, again! Unbelievable talent...and some of the other turners weren't that bad either. I've been Treasurer of SWAT for a few years now and can almost make the budget numbers add up - between turning projects. The remainder of my free time is spent....wait, I have no free time outside of SWAT. Other activities I do between SWAT projects are spending quality time with my wife, devotion to my new career in the Oil and Gas business, I'm also Treasurer of a professional organization (North Texas Measurement Association), eating, sleeping... well, you get the drift. I am truly honored to be associated with SWAT and every year look forward to the unbelievable talent and skill that you all bring to Waco!

PAST PRESIDENT, CLYDE LITTLE

After 37 years' experience in the electronics/computer world (mainly IBM), I decided to take up woodworking. Built a 24 x 60 shop and equipped it with woodworking tools, including a lathe that set idle for a year-didn't know what to do with it. I went to a Central Texas Woodturning meeting, where Stacey Hager was presenting. It turned out that Stacey and I had run around together at UT in the mid 60's and had not seen each other until the meeting. I subsequently became active in CTWA, learning woodturning from the best and eventually became president. I now have three lathes and lots of wood. I enjoy turning mesquite the most. Pat (my wife who is a past president) and I sponsor/host many classes in our shop, to include beginner's classes and national turners every year. It is a pleasure to be involved in a discipline with so many people that care about others and unselfishly share their knowledge. Because of that, I hope to help SWAT to continue to be the best symposium in the world, educating and sharing. I consider it an honor to be involved in such a community.



SUPPORTING CHAPTERS

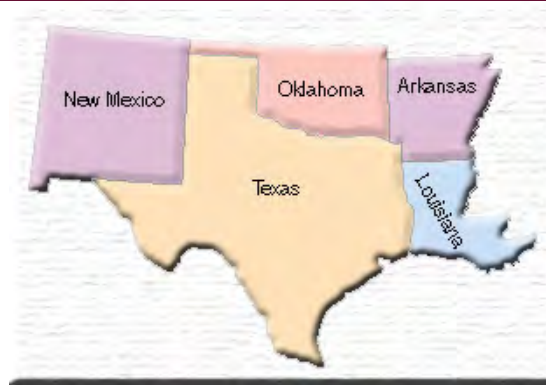

Abbr	Chapter	Area
AW	Acadiana Woodturners	Lafayette, LA
AW	Alamo Woodturners	San Antonio, TX
ALT	Ark-La-Tex Woodturners traderdon55@hotmail.com	Texarkana, TX
BW	Bayou Woodturners	New Orleans, LA
BLT	Borderline Woodturners cwieters@elp.rr.com	El Paso, TX
BVW	Brazos Valley Woodturners	Waco, TX
CAW	Central Arkansas Woodturners	Hot Springs, AR
COWA	Central Oklahoma Woodturners Assn	Oklahoma, OK
CTWA	Central Texas Woodturners	Austin, TX
CBW	Coastal Bend Woodturners	Corpus Christi, TX
CTW	Comanche Trail Woodturners	Midland, TX
CVW	Concho Valley Woodturners	San Angelo, TX
DAW	Dallas Area Woodturners	Dallas, TX
DSW	Diamond State Woodturners	Jacksonville, AR
ETW	East Texas Woodturners Association	Tyler, TX
GTW	Golden Triangle Woodturners	Denton, TX
GCW	Gulf Coast Woodturners Association	Houston, TX
HCT	Hill Country Turners	Kerrville, TX
HCW	Hunt County Woodturners, Inc.	Greenville, TX
LWT	Lone Star Woodturners	Spring, TX
NEOWTA	Northeastern Oklahoma Woodturners Assn	Tulsa, OK
NWOW	Northwest Oklahoma Woodturners	Enid, OK
PAT	Panhandle Area Turners Society celsea@yahoo.com	Amarillo, TX
SEOW	Southeast Oklahoma Woodturners engelwilson@fullnet.net	Idabel-Broken Bow, OK
SPW	South Plains Woodturners	Lubbock, TX
STW	South Texas Woodturners	Victoria, TX
WFW	Wichita Falls Woodturners handlebarsturner@aol.com	Wichita Falls, TX
WNT	Woodturners of North Texas	Ft. Worth, TX

LIST OF DEMONSTRATIONS

Demonstrator	Project	Page
Roy Alvarez	Creating a Skill Set	17
Sam Angelo	Blending Embellishments	21
	Hand Chasing Threads, The Castle Box	24
Sally Ault	A Sea Urchin Box	27
Eli Avisera	Avisera Blocks and Inlays	30
	Wood Turning Puzzle & Square Bowl	32
Donna Banfield	Patterns, Textures and Color 1	34
	Patterns, Textures and Color 2	36
Kevin Bassett	Angel Ornament	38
Brian Blohm	Casting and Finishing	43
Andy Chen	Turning Corian	48
	Segmenting, Beyond Basics	54
Buddy Compton	Texturing and Coloring an Offset Bowl	57
Rebecca DeGroot	Walking Bowl	61
Kurt Hertzog	Tips & Tricks for Perfection in Pens	68
	Taking Pen Presentation to the Next Level	71
Carl Jacobson	Embellishing with Milliput	74
	Making Your Own Natural Void	75
Lyle Jamieson	Are You With Me?	76
Marty Kaminsky	Sunburst Bowl	78
Alan Lacer	Skew Chisel	85
Pete Marken	A Vortex Bowl	88
Ken Nelson	Inlay Kit Assembly	96
Larry Randolph	Sandblasting	101
Brian Schrader	Three and Six Pointed Winged Vessels	105
Drew Shelton	Turning a Burl Cap	109
Jim Swank	Making Pen Blanks from Bottle Caps	113
Malcolm Tibbetts	Getting Started with Segmenting	115
	Compound Miters and Ribbons	
	Tubal Segmented Constructions	
Barry Todd	Shades of Tiffany	121
Larry Zarra	Mini Hollow Forms	125



TURNING 28

WITH ROY ALVAREZ

[<Link to List of Demonstrations>](#)

Creating a Skill Set



During my journey as a woodturner, I have been privileged to learn from some of the world's most distinguished production turners. Each turner has a unique trait or characteristic that not only sets them apart, it gives that turner his/her identity. I can assure you that there is so much to learn from all these experts yet trying to adapt to everyone's turning style or turning philosophy will prove to be overwhelming. At times, one style can be downright contradicting to that of a previous lesson or technique learned and vis-versa. So, the question remains: "How do I create MY personal skill set to ensure that I get the most consistent, productive and reliable results possible?"

It is my intent to feature two individuals that have vastly contrasting turning styles and philosophies in an effort to illustrate that by adapting the best of both worlds, one can develop a unique woodturning skill set that will have the greatest impact on your personal woodturning journey.

Mr. Nick Cook from Marietta, GA is the first true accomplished woodturner that I had the honor of meeting. The fact that he took his time to teach me and encourage me on my path was a tremendous boost to my confidence, but most of all, it allowed me to see and hear firsthand what a proper cut should be. I was also taken aback by how effortless the consistency he displayed in repeating the same cut repeatedly with such ease and fluidity of body control and movement. Nick continues to be a tremendous model to emulate.

Nick is known for his precision in producing sets of large, long-grain turnings such as architectural columns, architectural stoops and large bed posts. His hallmark of consistency is highly revered, and his turning style reflects this work. You can also see his philosophy at work in his development of Powermatic Lathes where Nick has implemented the "comparator arms" to better facilitate making exact sets of turnings. Nick's philosophy is: "I prefer to make many small cuts as opposed to one big cut because it leaves a much smoother finish...Make every cut as if it were your last; never, ever take the last cut-- that is the one that gets you in trouble."





Glenn Lucas is arguably the world's greatest production turner of usable ware. His ability to maximize his time at the lathe is no accident. Glenn has meticulously evaluated every aspect of the turning process and has developed a turning process that allows him to produce thousands of bowls and platters in a year's time, while maintaining a most rigorous global travel and teaching schedule. Glenn has by far impacted my woodturning journey more than anyone else. From his grinder set-up to his tooling techniques, Glenn has helped me maximize my limited time at the lathe. Glenn is constantly evaluating the turning and tooling process in

maximizing his time and materials for the greatest possible yield yet maintaining a tremendously high standard of product. Glenn's philosophy is simple: "If the final product looks right, and feels right, then it is right."

As different as both woodturners appear, the nexus where their talents and creativity are evident, is in the making of platters. I hope to adequately compare the turning style of these two gentlemen in producing platters that represent the finest of both individuals.

Prior to beginning the woodturning demonstration, we must revisit terms that will permeate today's lesson:

A. The first question is: What is education?

In its basic definition, education is simply an experience or series of experiences that create a profound change in an individual.

These two master woodturners have impacted my woodturning journey with many challenges and experiences that have led to a positive woodturning education.

B. The second term is schema.

Schema is defined as an individual's prior knowledge. Therefore, depending on your personal journey you will have amassed knowledge and skills that may be unique to your turning style, or you may be at the beginning of your journey and are seeking to evaluate different woodturning methods and philosophies. Your schema will be the driving force in how you experience this symposium.

My goal is to introduce methods and techniques that will help you evaluate and build your personal style by introducing philosophies, methodologies and techniques that are tried and true by these two masters of the craft, Mr. Nick Cook and Mr. Glenn Lucas.

Presentation Focus

- I. Evaluating a turning blank for the most aesthetic value
- II. Mounting the blank
 - a. Worm Screw with spacer
 - b. Faceplate and screws
- III. Dress the edge?
 - a. Advantage of dressing the edge
 - b. Disadvantage of dressing the edge
- IV. Truing the bottom of the platter

- a. Nick's technique
- b. Glenn's technique
- V. Evaluating the size of the foot for a platter
 - a. 2 1/2-inch jaws
 - b. 4-inch jaws
 - c. 50 percent of platter's overall diameter
 - d. 70 percent of platter's overall diameter
- VI. Bottom and side profile
 - a. Continuous curve
 - b. Roman Ogee
- VII. Sanding Techniques
 - a. Oil sanding
 - b. Dry sanding
 - 1. Hand
 - 2. Power
- VIII. Remounting the Platter to address the face
- IX. Surfacing the face
- X. Planning the platter profile
 - a. Nick's technique with textured rim
 - b. Glenn's traditional Irish inspired platter
- XI. Creating the platter profile
 - a. Aesthetically pleasing dimensions
 - b. Hollowing techniques
 - c. Scrappers
 - d. Sanding
 - e. Finishing



Photo gallery:





TURNING 28

WITH SAM ANGELO

[<Link to List of Demonstrations>](#)

Blending Embellishments



In this demonstration I will explore methods and techniques for changing the appearance of wood. Applying embellishments to lathe-turned projects is a major force in woodturning today. Scorching, coloring, texturing, and carving are a few of the options available that can alter the natural appearance of wood. Adding a few beads on a bowl would be an embellishment. Adding four or five different embellishments might be going too far. So “blending embellishments” might just be the correct way to view this topic. Adding an oil finish to a salad bowl or wooden plate will bring out the grain or figure in the wood. We have certainly changed the appearance of the wood by simply adding a finish: applying perhaps the most basic embellishment of all.

Embellishment’s list for wood turned items

My own playlists of videos relating to embellishing wood:

(Sam Angelo) <https://goo.gl/vQz4E5> & <https://goo.gl/xnQ1wL>

- Metal reactive paint
- Texturing
- Gilt cream
- Pyrography
- Burning/scorching
- Off-center work
- Metal leaf
- Inlay
- Coloring
- Carving

Adding Color from the inside of a hollow form

(This process will be discussed briefly, but with limited time, will not be included in the demonstration).

The pieces below represent one of my favorite lathe-turned items: hollow forms with a threaded lid and finial that have been colored from the inside of the vessel. The wood is Box Elder (*Acer negundo*). I begin this process by turning the hollow form to a wall thickness of ¼”

or less. I like to bleach the outside of the vessel to remove any color from the wood. This step provides a completely white canvas. I add a small amount of my first color into the opening of the hollow form. I use transtint dye which has been mixed with lacquer thinner. To apply the dye I use a pipette which is like a very long eye dropper. I normally begin with a darker color like blue or brown. I continue adding each color slowly until the dye stops wicking though to the surface. Take your time and let each “color” soak into the wood and allow to dry before adding a second color.

The dyes will wick through the walls of the hollow form following the grain and figure that is naturally in the wood. I then use an airbrush to apply a lighter color, usually yellow or amber, to the outside of the vessel. With this last step, the outside has been completely covered with color. I then finish with either a spray lacquer or an oil.



We can't improve on Mother Nature

The colors in a flower or a sunset do not need any help from me. When I first began working with wood I believed it was just wrong to paint wood. Now I believe that some wood deserves to be painted or stained or scorched. I do have a reverence for nature and a deep respect for how we use and conserve wood. But wood is not in itself sacred. However, I would never color cocobolo, kingwood, or lignum vitae. Trying to enhance these woods might be the best example of gilding the lily.



Below are photos of my work which include some of the techniques I will focus on during this demonstration. These techniques included in the work below are: airbrushing, metal reactive paint, texturing, scorching, off-center turning, and applying metal leaf.

Please contact me with any questions or comments. Sam Angelo





[<Link to List of Demonstrations>](#)

Hand Chasing Threads, The Castle Box

During this demonstration on thread chasing I will cover the elements of chasing both male and female threads as well as approaches for mating them together. Special consideration will be given to tools, sharpening, and wood selection. While completing a simple project, I will reflect on the rich tradition of thread chasing through the work of Bill Jones and others.

Castle Box



Chasing the male thread in Boxwood

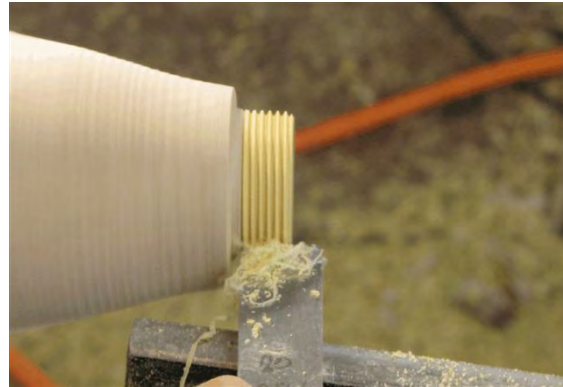

A major influence on my own skills as a thread chaser using traditional hand tools has been the British turner John Berkeley author of the book *All Screwed Up* and the DVD series *Screwples*. John has been an inspiration who has greatly influenced the direction of my own woodturning experience over the past ten years. The Castle Box, with threaded fitment, is one originally found in the book, *Puzzles Old and New* written in 1893 by Louis Hoffman. John Berkeley also presents his own interpretation of this threaded puzzle box in his book and DVD series. I will turn my own version of the castle box and add my own design ideas.

Castle Box design

I am a strong proponent of making prototypes to investigate form, shape, and design-as well as determining the best location for the join in a box or container. The display of castle boxes below contains some finished pieces as well as some which have been left solid for the sole purpose of exploring design.



The Process

**Note: For the "demonstration" piece that follows, I have turned this box with a slip fit connection only-no threads.*



A 2-1/2" x 4" Mahogany blank is held in long nose jaws ready for turning. A completed box rests horizontally atop the blank. The first step is to determine the length of the finished box, taking into consideration the wood lost that will be used for the male tenon. The approximate length is marked in pencil.



This photo shows the layout of the box drawn with pencil. At the top of the castle box, marked in black sharpie, will be the castellations later carved out with a "hub cutter."



Here I have defined the bottom of the box with a thin parting tool (nearest the chuck jaws). Moving to the left, the wider groove will become the male tenon, and finally the top of the box also marked with a parting tool. I have also formed a spigot on the left end of the blank to eventually hold the lid of the box for chasing.



These three photos show more layout details in red, a nearly completed surface with friction polish applied and the lid parted from the base. The last photo shows the completed lid held in the chuck jaws.





With the box once more reversed in the chuck jaws I am ready to cut the castellations. Using a cylinder of maple divided into 6, 60° segments as a guide, I mark off the 6 areas to be cared with the hub cutter shown in the next photo.



The lid completed. The brass hub cutter can be seen in this photo held by a 7mm pen mandrel.

The Finished Box



Please contact me with any questions of comments. Sam Angelo



TURNING 28

WITH SALLY AULT

[<Link to List of Demonstrations>](#)

A Sea Urchin Box



You first need to obtain a nice sea urchin. The Sputnik versions are sold by Craft Supply and others. The Alfonso, Purple, Green and White Mexican Urchins are a bit harder to find but Etsy and EBay are good sources. You might even have a local source...or a beach to find them on.

To make the sea Urchin strong you fill it with insulating foam. I use a brand from Home Depot called Great Stuff. There are 2 types...I use the one for windows...it doesn't expand quite as much.

First completely cover the sea urchin with plastic wrap or foil and masking tape to prevent any of the foam from getting on the shell.

Cut a large hole in the tape and plastic covering the hole at the top. Squirt in the foam...get it into all the areas. It will continue to "grow" until it gets firm so don't overfill...it goes everywhere and you will soon see why it is important to cover the shell completely with plastic wrap. If you overfill with too small a hole it can break the shell. If you get foam on the shell it will discolor in time even if you think you got it cleaned off.

Once the foam is cured remove the tape and plastic wrap.

You won't use the whole can of foam unless you are doing a large number of urchins but if you don't clean the tube with acetone immediately you won't be able to use it again.

To determine the size of wood blank required you need to decide what the diameter of the rim of the box insert will be and add a bit for rounding to a cylinder.

Measure the height of the urchin to determine the length of wood needed for the insert, add the desired height of the lid and the foot (including a longer than usual tenon) plus the amount of wood needed for 2 tenons and 2 parting cuts and that is the length of blank you will need for the box. If you want a finial from the same wood add that length to the blank or find a pen blank that is the same wood to use for the finial. A contrasting finial or one made from a different material can be effective too.

Round the blank to a cylinder, make a tenon on both ends and part between the base and the lid. Put the base into the chuck and form the lip that will overlap the hole in the shell.

Shape the outside of the box (this part won't be seen) to the desired depth. Create a small tenon on the bottom for insurance.

Cut in a step for the lid to rest on making sure it being cut into solid wood. If you make the interior too wide you may cut off the rim of the box.

Make sure the sides of the recess for the lid are perfectly straight and deep enough to provide a stable spot for the lid.

Hollow the inside remembering that it shouldn't be too deep since it is a small box. I generally make the depth about the same dimension as the width of the interior. I gently round the bottom rather than making straight sides.

Sand and finish the rim and inside. No need to finish the outside since it will be hidden inside the shell.



Put the lid blank into the chuck. Determine the width of the lid and the width of the tenon which will fit into the recess in the base of the box. Give some thought to how the rim of the base and lid shapes work together. The lid can be wider than the rim of the base, the same diameter or narrower. It is a design choice.

Make sure the tenon on the lid is perfectly straight. The fit should not be tight...this is a one handed opening box and you don't need a tight fit to work on the lid.

Once the tenon is the right size, create a slight dovetail inside the tenon going deep enough to get into solid wood and then create a curved recess in the lid. Sand and Finish the tenon, rim and inside the lid.

Rough out the shape of the top of the lid as far as possible while it is still in the chuck. You can support the lid using the tailstock with a non-marring insert while you are shaping.

Once you are close to the desired shape part it off (the wood remaining in the chuck is for the foot) and turn it around in a chuck with the jaws expanding into the lids dovetail recess. I use a piece of paper towel to help avoid any marks from the chuck jaws. Support the lid with the tailstock. (I use the Drozda point with the smallest pin) and finish turning the top of the lid. Take very light cuts.

If you are making a tall finial you can make the finial separately from the lid with a 1/8" or 1/4" tenon on the end...make the corresponding recess in the lid and connect them after both the lid and finial are completed.

For the foot, measure the area to be covered by the shell side of the foot. Round to a cylinder and cut a tenon that will be inserted into the shell. Cut a small tenon on the end of that tenon to use when finishing the bottom of the foot.

Shape the part of the foot that will touch the shell with an undercut so the shell will fit up into it if needed.

Shape the outside of the foot making sure the base is wide enough to give support to the shell. Part off with as much of an undercut as possible so there isn't as much turning to do when it is turned around in the chuck. Sand and finish all the accessible areas.

Secure the small tenon into the chuck and support the foot area with the tailstock for as long as possible. I use the Drozda point with the smallest pin for this. Shape the underside of the foot as far as possible then remove the tailstock and complete the cutting. Sand and finish the underside.

If you make a foot with a pedestal it can be made in one piece or in two pieces similar to adding a finial.

Using a rotary tool with a small cylindrical sander or abrasive bit, start cutting out the shell to the diameter of the insert. Measure carefully and draw a line at the proper diameter. Shape the hole slowly so you don't crack off any shell. Keep trying the insert. Only take as much foam out as needed. Don't make the shell too tight against the wood in case of movement of the wood. Glue insert into the shell with 5 minute epoxy.

Using a smaller abrasive bit make the hole for the foot tenon in the bottom. Keep trying for size...again don't make the fit too tight.

If you have a tall finial and/or a pedestal foot you will need to take extra care to line them up since shells are not symmetrical. Glue in the foot with 5 minute epoxy.





TURNING 28

WITH ELI AVISERA

[<Link to List of Demonstrations>](#)

Avisera Blocks and Inlays



Prepare the Blocks with Star in the Center

Turning a Products with the Blocks

Turning Box and Goblet from Avisera Blocks

Project Design

Finishing





TURNING 28

WITH ELI AVISERA

[<Link to List of Demonstrations>](#)

Wood Turning Puzzle & Square Bowl

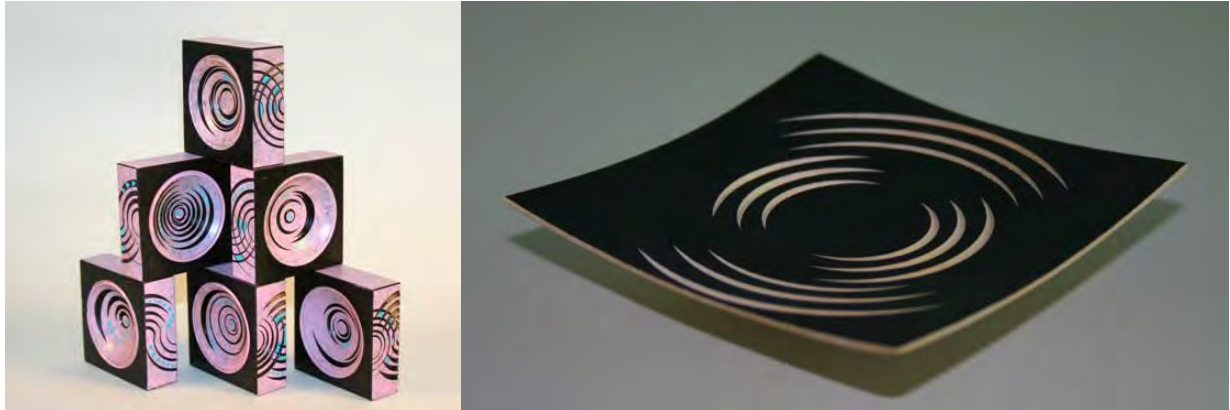

Turning a Square Shape

Combination of Acrylic Paint and Wood

Technics of Turning Square Bowl

Use the Tools Effectively

Decorate with Off-Center Technics





[<Link to List of Demonstrations>](#)

Adding Gilder's Paste to Your Burned and Carved Patterns



Illusions in Wood - Red Herringbone Basket

Walnut sapwood turned green to final thickness. Pyro-engraved pattern interior and exterior. Colored with black gilders paste as a base, with red gilders paste floated over the surface. Dimensions: 10 ½"/266 mm wide by 2 ½"/63 mm high.

All the techniques demonstrated during this rotation and taught in the workshop are used in the creation of my series, Illusions in Wood.

The idea behind this body of work was initially inspired by Harvey Meyer's Baskets of Illusion series. Harvey had turned a large green cherry bowl to final thickness, and allowed it to warp as it dried. I was intrigued by this creation because it truly deceived the viewer into believing that it was a woven basket, and the slouch or warping completed the illusion. I was inspired to create an entire body of work that would deceive the viewer into believing it as something that it was not. It could be ceramic, pottery, glass or metal – until they picked it up to discover the deception.

1. Start with your story board or burned/carved woodturning. Using either an airbrush, or paint brush, cover the entire piece a solid color. Dark colors work best, especially if your pattern as created using woodburning tips. I use acrylic paints in black or dark blue.

2. Allow your paint sufficient time to dry. If you used an airbrush to apply your paint, your piece will dry quicker. If you used a paint brush, you may need to apply more than one coat, allowing drying time in between coats.
3. Select your choice of color/gilders paste. Hold a firm make-up sponge between your thumb and index finger, and squeeze so that you create a curved or radius surface. Dab this curved surface into the gilders paste to pick up some color. If your gilders paste is dry, use a few drops of mineral spirits directly onto the paste in the tin to re-activate it.
4. Keeping the sponge curved, lightly blot the top surface of your work. The goal is to keep the color on the surface of your carved/textured pattern, and avoid getting the color into the recessed areas. Do not drag your sponge across the surface, because dragging will put color into those recesses.
5. Continue to apply color in this manner until you have finished.
6. Allow this to dry for at least 12 hours.
7. Apply a second coat, repeating steps 3 through 6.
8. After final color coats are applied, allow to dry for 24 hours, and seal using your choice of spray finish. I use satin lacquer.
9. When spraying finishes, always do so in a well-ventilated area, or outdoors. For best results, avoid spraying lacquer when there is high humidity, low/cold temperatures, or when it is raining.



Ceremonial Spirit Vessels

*Turned cherry and walnut with genuine copper gilded bowl. Hand-carved leaves.
4" h x 5" w.*



[<Link to List of Demonstrations>](#)

Complete the Illusion with Color Using Milk Paint and/or Gesso



Holly Forms, with Black Gesso, Carved

All the techniques demonstrated during this rotation and taught in the workshop are used in the creation of my series, Illusions in Wood.

The idea behind this body of work was initially inspired by Harvey Meyer's Baskets of Illusion series. Harvey had turned a large green cherry bowl to final thickness, and allowed it to warp as it dried. I was intrigued by this creation because it truly deceived the viewer into believing that it was a woven basket, and the slouch, or warping completed the illusion. I was inspired to create an entire body of work that would deceive the viewer into believing it was something that it was not. It could be ceramic, pottery, glass or metal – until they picked it up to discover the deception.

1. We'll begin with your story board, or one of your woodturnings. Your turning should have a tenon still attached so that it can be held in a chuck on the lathe. There is no turning; the lathe will only be used to hold your work while the paint is applied. Fix your turning in the chuck.
2. Cover the lathe bed with a cloth or plastic to catch paint drips.
3. Using a fine bristle brush (not a foam paint brush or glue brush) apply a coat of the milk paint or Gesso to your story board or turning. If using a flat story board, apply the paint in even strokes in one direction, and try to keep paint lines to a minimum. If applying paint to a turning held in a chuck on the lathe, rotate your turning by hand, using the hand-wheel, while spreading the paint on the turning. If your paint or Gesso is thick, it will leave more

'paint lines' on your piece, so it may be helpful to thin it down with a few drops of water. The viscosity of the Gesso/Milk paint should be like milk.

4. Use the hair dryer on a low heat setting to help the paint dry.
5. Using abrasives (starting with grits 320, 400 or 600, depending on how many paint lines are visible, lightly knock them down. Do not sand through the coat of paint. Wipe off with clean paper towel or soft cloth.
6. Apply a second coat of paint as described in No. 3, above.
7. Dry the coat of paint as described in No. 4, above.
8. Use 800 or 1000 grit abrasive to lightly knock down any paint lines. Do not sand through the second coat of paint. Wipe off with clean paper towel or soft cloth.
9. Apply third coat of paint, repeating steps 3-5.
10. Use 4/0 steel wool in a circular pattern to buff and polish the paint. Wipe off with a clean paper towel or soft rag.
11. In a well vented space, or go outside, spray light coats of Krylon Matte over the painted surface. This will protect your paint from marring while you proceed with the next steps.
12. Select the cutters (rotary burs or cutters, reciprocating cutters) to create the pattern you desire on your painted piece. You may use my samples of patterns, or your own.
13. While wearing safety glasses and magnifiers (if desired) carefully use the cutters to remove the paint all the way to the bare wood to show your pattern.
14. Reverse chuck your turning to clean up the bottom, and/or remove the tenon if desired. Repeat steps 3-5 to blend the paint. Sign your work.
15. Once finished, apply spray finish of your choice 24 hours later. I use Satin Lacquer.



Illusions in Wood - Steam Punk Silver Metal

Walnut sapwood turned green to final thickness. Pyro-engraved pattern interior and exterior. Colored with black gilders paste as a base, with silver gilders paste floated over the surface. Dimensions: 9"/228 mm wide by 1"/25 mm high.



TURNING 28

WITH KEVIN BASSETT

[<Link to List of Demonstrations>](#)

Angel Ornament



I mount the stem between centers with the center in the pith or very close to the pith.



The basic shape and proportions are roughed out for skirt bottom natural edge to waist bust and neck ... the Head is done separately. A tenon is cut to reverse the turning.



You can drill out the lower body to begin hollowing or just dig in with a bowl gouge

The lower body skirt is hollow to the waist.



Waist detail and upper body is roughed out to shape. At this point the body is removed from the normal chuck and situated on a compression chuck to hollow the upper body and neck area.



The piece is clamped into the compression chuck using the small cone Live center to insure proper alignment. The final form of the upper body can now be turned and hollowed gently. Note that the pith has been totally removed.



At this point the only support is through the compression chuck. Proceed to hollow the upper body and neck with great care. A light touch is essential.

Once the upper body is hollowed the piece is removed from the compression chuck and the next step to fit the head begins.



The head is formed and a tenon cut to fit the body.

The head is parted and reversed to a chuck to finish the top of the head.



The head and body are now complete. Which brings us to the wings.



The wings begin as a 1/2 - 3/4" thick x 4" square or even rectangular piece of hardwood. In this case green Yaupon Holly.



Mount the stock between centers with the center offset toward on end.

The wing side profile is created as well as the standoff distance from the body. This face will be the body side of the wing.



The wing is reversed, and the profile followed to create a thin wing.

The use of light and wood translucency can be helpful when turning green wood to a gossamer thinness. The remainder of the wig work is done on the lathe. Cutting the final wing shape can be carefully done on the band saw. The wings can be pierced or colored or decorated in any way you decide.



I use a Foredom carver with a round bit to create a cup to facilitate mounting the wing to the body. The Foredom can also be used to shape the wing.



The wings and head may now be adjoined to the body. Leaving only the Halo and a means to hang the ornament. For this task a Brass wire is used.



Halo and hanger loop. By drilling down and through the wing attachment point addition strength is added to the bond between wing and body.



Project complete and ready for fine detailing. Could be pyrography, dyes or paint, piercing, texturing. Other areas of investigation on this basic idea are altering body length, depth of curvatures, adjusting proportions. Changing wing shapes and profiles. In other words, as is everything in wood turning, the possibilities are endless.



TURNING 28

WITH BRIAN BLOHM

[<Link to List of Demonstrations>](#)

Casting and Finishing

A few years ago I introduced the “flip cup” or “dirty pour” casting technique to the resin community after seeing acrylic paint artists using this method on their canvas works. The short and sweet explanation of this method is that the artists will pour all the colors of their acrylic paint into a single cup and then pour that cup onto the canvas. The result is an unexpected, yet beautiful canvas where the colors have unique separation and beautiful swirls. In watching videos of these artists, I was intrigued by the style, and I decided to test it out in resin casting. When I cut up that first test block, I was hooked. The blanks were beyond gorgeous, and I shared my results in a Facebook group called “Pen Blanks Resin Casting.” Within hours of posting my blanks, all of them were sold, and I was out in the shop making more.



Now that you know my background with this method, let’s jump in to how you can do this in your own shop. In order to do the Flip Cup Method for casting resin, it is important to note that there are no restrictions on type of resins. You can use any resin you choose, just as long as you work within the guidelines for that medium (i.e. temperature to pour at, whether you need to cast under pressure, etc).

For the sake of ease in this example, we will use Alumilite, but you can generalize these instructions to any Resin you prefer to work with.

Before you begin, you will need the below supplies:

1. Kitchen/Digital Scale (Heads up: your spouse may *not* appreciate you grabbing one from the pantry. Your best bet is to buy one that can stay on your casting bench. Learn from my mistake.)
2. Infrared Thermometer Gun
3. 300g Alumilite Clear Part A
4. 300g Alumilite Clear Part B
5. Six 9oz Paper Lined Disposable Cups (Do NOT buy wax lined – they must be paper only.)
6. Three colors of Mica Powder, Pigments, or Dyes. For this example, we will use Mica Powder.
7. Three Jumbo Popsicle Sticks
8. Large Disposable Plastic Container (I re-use 1L water bottles with the top cut off)
9. Casting Block Mold
10. Pressure Pot
11. Air Compressor
12. Stoner Mold Release (determined by resin type)
13. Latex/Rubber Gloves
14. Respirator
15. Eye Protection

NOTE: If you're wanting specific links to each of the items and where I buy from, I've got them listed at the end of these instructions.

The Flip Cup Pour Method

1. To start, put on your Eye Protection, Rubber Gloves, & Respirator.
2. Take your Block Mold and your Mold Release. Spray the inside of your mold. Set aside.
3. Using your Kitchen Scale, weigh out 50g of Alumilite Part A into 3 of your paper cups.
4. Using your Jumbo Popsicle Sticks and your Mica colors, scoop out 3 heaping scoops of Mica Powder into each of your cups. The amount of Mica Powder you use in your casting will be entirely dependent on what you want your final product to look like.
5. Stir the Mica Powder into your Resin. When you think you're done. Continue stirring. Remember: You can't over-stir, but you can under-stir. The better job you do of mixing your mica into your resin, the better your outcome. Best method is to stir about 20 times clockwise, scrape the edge of the cup to grab anything stuck to the side, and then stir counterclockwise. And repeat.
6. Using your kitchen scale, weigh out 50g of Alumilite Part B into your remaining 3 paper cups.
7. Pour your 50g Part B into each of the Part A cups. This will give you 100g of each color Resin. (If you want to check if you have enough Mica Powder in your cup, you can pick up the Popsicle Stick and let the resin drip off it back into the cup. When looking at the Resin dripping off the bottom of the stick, if you can't see the brown tint of the stick, then you have enough mica to create an opaque blank.)

8. Stir. Stir. Stir.
9. Grab your infrared Thermometer, and check the Temperature of each of your mixtures. Once *one* of the cups hits 95 degrees F, you will be ready to move on to the next step. If none of your cups are at 95 degrees F yet, just continue stirring and checking the temperature intermittently.
10. Once you've got one of your cups at 95 degrees F, grab your 1L water bottle with the top cut off, and pour all 3 cups of Resin into this container. The first color you pour in will be your accent color, and the 2nd and 3rd colors will battle for dominance.
11. Grab your block mold, place it upside down on the top of the cup with all the resin. Ensure a good seal.
12. Flip the mold with the resin cup over, set it down on the table, and then pull the cup of resin up to release the resin into the mold.
13. Allow the resin to drip into the mold, being mindful to not allow too much time to pass.
14. Grab your mold, place it in your pressure pot.
15. Seal the pressure pot and introduce air to 40 psi.
16. After 4 hours, you can release the air from the pressure pot, and pull the mold. Remove the casting block from the mold. Give it a few more hours to fully cure before cutting your block up.
17. Take lots of pictures, and make beautiful pens.

The Casting List

Here is a list of everything I use to cast blanks. There's obviously more than one variety, but this is just to help guide you.

1. Pressure Pot – 2 ½ Gallon Air Pressure Paint Tank (Harbor Freight)
<https://m.harborfreight.com/2-1-2-half-gallon-pressure-paint-tank-66839.html>
2. Air Compressor – 8 gal. 2 HP 125 PSI Oil Lube Air Compressor (Harbor Freight)
<https://m.harborfreight.com/8-gal-2-hp-125-psi-oil-lube-air-compressor-68740.html>
3. Safety Goggles – Safety Glasses with Clear Lenses(Harbor Freight)
<https://m.harborfreight.com/safety-glasses-clear-99762.html>
4. Compressor Line filter – 1/4 in. Air Line Filter/ Regulator with Gauge (Harbor Freight)
<https://m.harborfreight.com/14-in-air-line-filter-regulator-with-gauge-68228.html>
5. Respirator – 3M Dual Cartridge Respirator Assembly (Amazon)
https://www.amazon.com/gp/aw/d/B00079FOK0/ref=mp_s_a_1_3?ie=UTF8&qid=1518016781&sr=8-3&pi=AC_SX236_SY340_QL65&keywords=respirator+mask&dpPI=1&dpID=41N4-bKd2WL&ref=plSrch
6. Alumilite Resin – Alumilite Clear 8lb Kit (TurnTex)
<https://www.turntex.com/product/casting-with-alumilite/alumilite-clear-8-lb-kit-detail>
7. Block Mold – 6" x 5-1/4" x 1" Block Mold(PTownSubbie)
<https://ptownsubbie.com/collections/block-molds/products/6-x-5-1-4-x-1-block-mold-blue>

8. Pressure pot rack – 2 ½ Gallon Mold Rack System (PTownSubbie)
<https://ptownsubbie.com/collections/mold-rack-systems/products/2-5-gal-pressure-pot-rack>
Mold Rack is Optional, but Recommended
9. Mica Powders – Caster’s Choice Mica Powders (Various Vendors)
Turners Warehouse, TurnTex, PTownSubbie, Wood-n-Whimsies, Woodcraft of Columbus, Ohio, House of Resin (UK), and William Wood-write (CA)
10. Popsicle sticks – Jumbo Craft Sticks (WalMart)
<https://www.walmart.com/ip/Horizon-Group-USA-Jumbo-Wood-Craft-Sticks-300-CT-3pk/46691378>
Can also find these on Amazon
11. Paper Cups – 9oz Paper Cups (Amazon)
https://www.amazon.com/Dixie-Round-Paper-Cold-Count/dp/B07D6TW1NP/ref=sr_1_1_sspa?keywords=dixie+9oz+paper+cups&qid=1554066085&s=gateway&sr=8-1-spons&psc=1
Can also find these at WalMart
12. Kitchen Scale – Digital Food Scale (Amazon)
https://www.amazon.com/dp/B01E6RE3A0/ref=dp_prsubs_2
13. IR Thermometer – Infrared Thermometer Temperature Gun (Amazon)
https://www.amazon.com/Champion-Thermometer-Temperature-Automotive-Maintenance/dp/B01DQBP8BA/ref=redir_mobile_desktop?encoding=UTF8&keywords=ir%20thermometer%20gun&pi=AC_SX236_SY340_QL65&psc=1&qid=1518015063&ref=mp_s_a_1_2&sr=8-2-spons
14. Rubber Gloves – Vinyl Gloves
https://www.amazon.com/gp/aw/d/B008N0W9IA/ref=mp_s_a_1_12?ie=UTF8&qid=1518015153&sr=8-12&pi=AC_SX236_SY340_QL65&keywords=rubber+gloves

Other Resin Options

1. Liquid Diamonds
<https://turnerswarehouse.com/products/liquid-diamonds-epoxy-casting-resin>
2. Polyester Resin (Silmar 41)
WoodNWhimsies.com
USComposites.com

Other Mica/Pigment/Dye Options

1. PearlEx – Hobby Lobby
2. Alumilite Dyes – Turners Warehouse www.turnerswarehouse.com
3. Divine Island Pigments - <https://divineislanddesign.com/collections/divine-pigments>

Examples

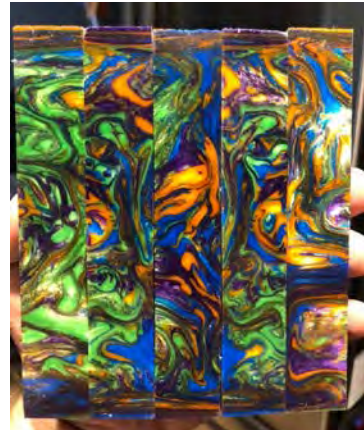
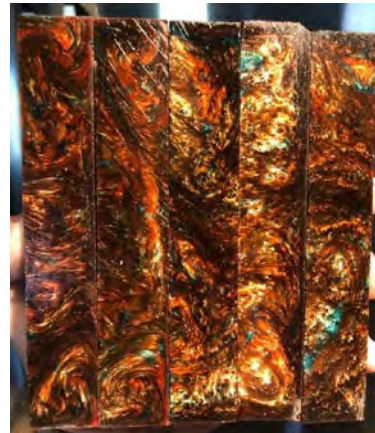



[<Link to List of Demonstrations>](#)

Turning Corian

Corian was invented by Du Pont in 1967. Originally it was based on acrylic polymer with particulates added to give it a granite look. There are many imitation products on the market since the Du Pont patent ran out and they are collectively called solid surface materials. Some of these are not acrylic based. They all require certification by the manufacturers to purchase, so does the special adhesive. There are two commercial sources for customers not certified: <http://solidsurface.com/> and Art Specialties International (209 St. Mary's Street Lancaster NY 14086, 1-800-724-4008) but the best is your local countertop installer.

Corian is usually available only in 12 mm (0.47") thickness. For thick applications you have to laminate it. Since the special Corian adhesive is not available to non-certified individuals, one can use cyanoacrylate (CA) glue. I use the thin and medium viscosity varieties. You can build turning blanks in segments or use solid sheet if it is available.

Corian is a hard material and wears out turning tools quickly. Therefore, I approach it by building blanks so as to minimize turning.

The first step is to design the vessel. The sketch below shows a design.

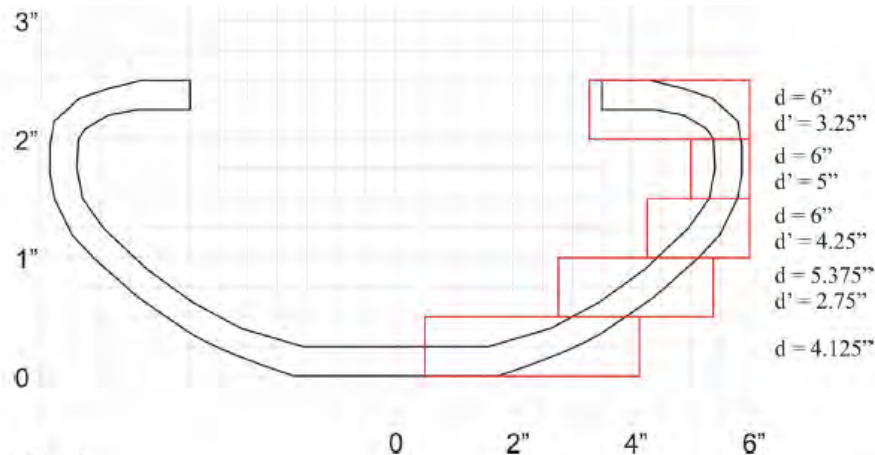

Fig. 1

Layer	n = # of seg	m = miter angle	d = OD	d' = ID	w = width of seg	l = length of seg	l' = short length	Total board length	T = thickness
1 (Base)	1	45	4.125						0.5
2	12	15	5.375	2.75	1.36	1.440	0.712	14.46	0.5
3	12	15	6.000	4.25	0.95	1.608	1.100	17.80	0.5
4	12	15	6.000	5.00	0.59	1.608	1.294	18.96	0.5
5	12	15	6.000	3.25	1.43	1.608	0.841	16.25	0.5

Method one (Segmented):

1. Cut a 4.125" square piece for the base as in the sketch, or glue up pieces and trim to size.
2. Cut the four corners off to make an octagon using the formula $x = d/3.414$ to find where to cut at 45°.

3. Find the center and dimple with a center punch.
4. Mount a waste block on a scroll chuck or faceplate, round off the corners and true up the surface (Fig. 2).



Fig 2



Fig 3

5. Glue the first layer onto the waste block with CA glue applied in a cross fashion (Fig 3) and apply pressure on the Corian with the point of the live center in the dimple (Fig. 4).
6. After the glue sets in a few minutes, back off the live center, turn the disc round and remove the middle portion of the first layer to $\sim 1/4$ " deep and $2\ 3/4$ " diameter (ID of the second layer found in the sketch) with a profile in the sketch. True up the rim (Fig. 5).



Fig 4



Fig 5

7. Make the rest of layers by cutting segments with a Wedgie Sled (Fig. 6) according to the dimensions in the table.



Fig 6

8. Tape segments together with duct tape and tighten them with hose clamps making sure all segments are lined up flat with each other (Figs 7A, 7B).
9. Apply thin CA glue to joints between segments until the glue stops seeping in (Fig. 8). PUT A SHEET OF PLASTIC UNDERNEATH SO THAT THE RING WOULD NOT BE STUCK TO THE SUBSTRATE.



Fig 7A



Fig 7B



Fig 8

10. Mount the second layer on the lathe by holding the ring against the first layer with a centering cone mounted on a live center and turn a taper (Fig. 10) so the diameter approximates the first layer (4.125" in this case). Sand the surface of the ring with reduced diameter flat with 60 grit sandpaper glued to a piece of granite.



Fig 9 All layers



Fig 10

11. Apply medium viscosity CA glue to the rim of the first layer and push the second layer on with a centering cone mounted on a live center (Fig. 12).



Fig 11 All ready to glue



Fig 12

12. Round the outside of the newly attached ring and turn the inside so that the wall is $\sim 3/8"$. True up the surface (Fig. 13).
13. Repeat steps 10 - 12 for layers 3 and 4.
14. With layer 5, mount the ring on a chuck with jumbo jaws and turn a depression in the middle leaving a rim of $\sim 3/8"$ wide (Fig. 14).



Fig 13



Fig 14

15. Apply medium CA glue to the rim of layer 4 and attach the top layer by pushing the top layer with a centering cone on the live center (Fig. 15). Finish turn, sand to 800 grit and buff with Tripoli and white diamond (Fig. 16)



Fig 15



Fig 16

Method two (from solid sheet):

1. Cut square pieces using the "d" in the sketch.
2. Cut the four corners off to make octagons (Fig. 17) using the formula $x = d/3.414$ to find where to cut at 45° .
3. Find the center on each piece and dimple with a center punch.
4. Mount a waste block on the chuck, round off the corners and true up the surface (Fig. 18).



Fig 17

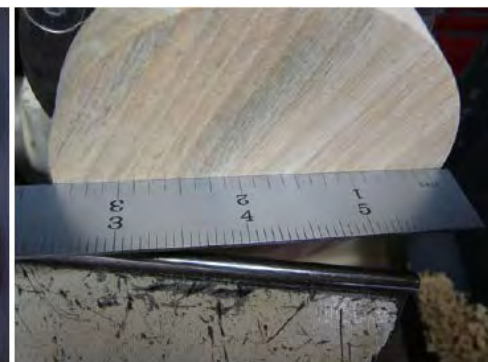

Fig 18

5. Glue the first layer onto the waste block with CA glue applied in a cross fashion (Fig. 19) and apply pressure on the Corian with the point of the live center in the dimple (Fig. 20).



Fig 19



Fig 20

6. After the glue sets in a few minutes, back off the live center, turn the disc round and remove the middle portion of the first layer to $\sim 1/4$ " deep and $2\ 3/4$ " diameter (ID of the second layer found in Fig. 1) with a profile in the sketch. True up the rim (Fig. 21).
7. Sand flat (with 60 grit sandpaper glued to a granite slab) the face of the second layer that will be attached to the first. Alternatively, remove $\sim 1/16$ " of Corian from near the center up to $2\ 3/4$ " and true up the rim with the layer pressed against the first layer by the live center (Fig. 22).
8. Push the second layer against the first one on the dimple with the live center. Trace the first layer onto the second with a pencil. Apply a healthy "bead" of CA glue inside the pencil mark ($\sim 1/4$ " inside pencil mark) all the way around and quickly push it onto the first layer with the live center on the dimple (Fig. 23).



Fig 21



Fig 22



Fig 23

9. After the glue sets in a few minutes, round off the outside (Fig. 24A), remove the center disc ($2\ 3/4$ " dia.) with a thin parting tool (Fig. 24B), smooth the inside and true up the rim (Fig. 24C).



Fig 24A



Fig 24B



Fig 24C

10. Repeat steps 7 – 9 for layers 3 and 4.

11. Turn the inside to nearly final profile.
12. On the top layer, push the octagon bottom side out with the live center against the previous layer. Round off the outside and turn away the middle section (Fig. 25A) according to the profile in the sketch (Fig. 25B). (You do not need to remove the center 3" portion.)



Fig 25A



Fig 25B

13. Glue the top layer on and part away the center 3 1/2" disc. Finish turn the vessel. Sand to 800 grit and buff with Tripoli and white diamond.

Website:

<http://www.jerrybennettart.com/index.htm>, Jerry Bennett



[<Link to List of Demonstrations>](#)

Segmenting, Beyond Basics

It is relatively easy to make a segmented vessel with one species of wood but the result would be rather bland. In this demo I will show some ways of enhancing the segmented turning to give it the wow look. I will first show how to add “feature rings” to the design. I will then show you the basics of making essentially a “basket elusion”.

The sky is the limit when it comes to the design possibilities of a feature ring. Geometric patterns, flowers, landscapes and all sorts of other thing can all serve as inspiration. The first part of the demo will be making diamonds.

Making a Diamond Feature Ring:

1. Two species of wood of contrasting colors, beech and blood wood in this example, are cut into small rectangles (Fig. 1).
2. Each rectangle is then cut diagonally into triangles (Fig. 2A, 2B).
3. Two triangles, one of each color, are glued into a rectangle (Fig. 3). (Four of these rectangles are required for each segment.)

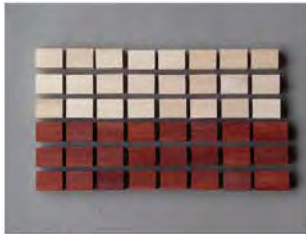

Fig. 1



Fig. 2A



Fig. 2B



Fig. 3

4. One end of the triangles (base of the blood wood in this example) is trimmed off to expose some beech (Fig. 4).
5. Pairs of these are glued together by the trimmed end (Fig. 5).
6. A narrow strip along the blood wood side is ripped off to expose some beech (Fig. 6).
7. The resulting pieces are then glued together pair-wise to form a rectangle with a diamond in the middle (Fig. 7).



Fig. 4



Fig. 5

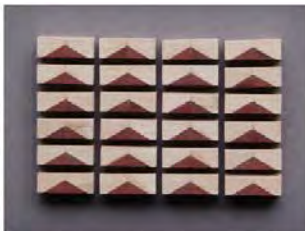

Fig. 6



Fig. 7

8. The ends of these segments are mitered (Fig 8, next page).
9. A partition is added (Fig. 9) to all but two of the segments (Fig. 9).

10. The segments are glued into two halves with the segments without the partition at one end of each half so that both ends of the halves have no partition (Fig. 10).
11. Check to make sure the two halves have no gaps in between when clamped together. If there is true up the ends by lightly sanding. Insert partitions and glue the halves into a ring (Fig. 11).

Depending on the size of the vessel, the size of the pieces constituting each segment could be quite small and thus requires special techniques for safe operation. I will share these techniques with you at the demonstration.



Fig. 8



Fig. 9



Fig. 10



Fig. 11

Basket Illusion:

Tom Lohman developed a system that can create very intricate and sophisticated patterns with thousands of segments. The system is essentially a modification of an open-segment system. It uses as many as 144 segments per layer, creating stunning patterns as shown below.



segmentedturning.org
Tom Lohman

By Tom Lohman



By Russ Braun

Obviously for something this complicated it requires some special setup as shown below.

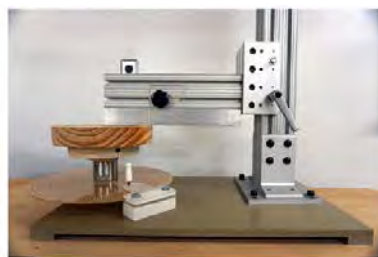

- Stop
- Indexing wheel
- Alignment pin
- Detent

And the glue-up is more like open segments rather than closed segments, one segment at a time.



References:

Brown, E. E. and Brown, C., Polychromatic Assembly for Woodturning, 113 pp., Linden Publishing, 1982.

Hampton, R., Segmented Turning, A Complete Guide, 151 pp., GMC Publications, 2003.

Nish, D., Woodturning with Ray Allen, 137 pp., Fox Chapel Publishing, 2004.

Tibbetts, M. J., The Art of Segmented Woodturning: A Step-by-Step Guide, 184 pp., Linden Publishing, 2004.

Smith, W., Segmented Wood Turning, 64 pp., Schiffer Books, 2007.

Keeling, D., Segmented Turning: Design, Techniques, Projects, 182 pp., Tauton Press, 2012.



TURNING 28

WITH BUDDY COMPTON

[<Link to List of Demonstrations>](#)

Texturing and Coloring an Offset Bowl



Blank Layout

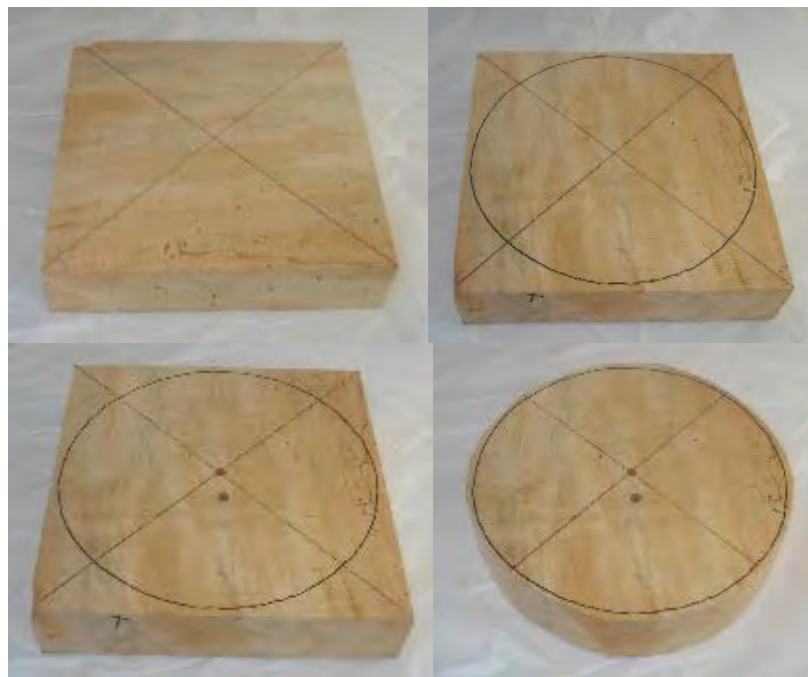

- 8X8X2 Blank – Will vary in size depending on project.
- Mark center on the top of the blank. If the blank is square scribe the blank round.
- Drill 2 holes in the top of the blank. I use an 11/32 bit for a 3/8" screw chuck. One hole in the center of the blank and a second hole 1" from the center hole for offset bowl.
- Cut the corners off the blank.

Lathe

- Mount the blank on a screw chuck in the center hole. May need spacers on the screw chuck to assure a tight fit.
- Round out the blank.
- Shape the bottom of the piece. Set the tenon on the base. The tenon will need to be approximately 4" in diameter and a proud 1/4" in depth. This diameter will insure you have enough room to cut the second tenon. Keep the tenon flat as possible, which will help when you turn the second tenon.
- Sand the bottom to finish. Apply sanding sealer. Oil finish or a finish of choice.

Shape the Top

- Attach to jaws chuck and shape the top of the piece. Make the top slightly curved from the edge to the center.
- After finishing the top – you may need to check the depth of the second hole to make sure it is still deep enough for the screw chuck.
- Sand the top to a smooth surface.

Texture and Color the Top



- Color the top of the piece. I will use a darker color for the first color.
- Texture the top (I use the Merlin grinder with the 8-tooth chain).
- Sand off the top after texturing.
- Choose colors that go with the initial color used on the top. Add whatever you like or until you get the look you desire.

Set the Second Tenon



- Turn blank around and attach to the screw chuck on the second hole.
- Turn second tenon for the offset bowl.

Turn or Hollow Offset Bowl



- Attach the piece to a jaw chuck on the second tenon.
- Turn or hollow the bowl form on the top of the piece.
- Sand bowl portion to finish.

Remounting Jaws



- Will need to put the piece on the remounting jaws.
- Dress the base of the piece.
- Sand to finish.

Finish



- Apply the finish of your choice. I use a satin lacquer for the first few coats and then go to a gloss lacquer.



TURNING 28

WITH REBECCA DEGROOT

[<Link to List of Demonstrations>](#)

Walking Bowl

During this demonstration, I will be going over basic design concepts and walking through the steps to create a three-legged “walking bowl” in my own style. I will work my way through the process of basic bowl turning, plotting an oversized foot, drilling and power caving the foot into “hips”, turning the spindles for the legs, cutting the legs apart at the appropriate angles, using splines to reinforce the leg joints, then reassembling the parts into a finished piece. If there’s time left over, I may go over other processes to reinforce the leg joints.

Tool and Equipment Needs

- Bowl gouge
- Spindle gouge
- Square scraper or parting tool
- Small faceplate and screws
- Four-jaw chuck with 2 inch jaws
- Band saw
- Coping saw or dovetail saw
- Rotary carver with variety of fine to aggressive burrs
- Drive center
- Live center
- Hand drill with drill bits
- Jacobs chuck
- Scissors
- Pencil

Material Needs

- 6x6x3 inch bowl blank
- 1x1x8 inch spindle blanks (x3)
- 1/64 inch thick veneer sheet
- Two-part epoxy or medium CA glue
- Cardstock paper
- Sandpaper
- Desired finish

Design and Personality

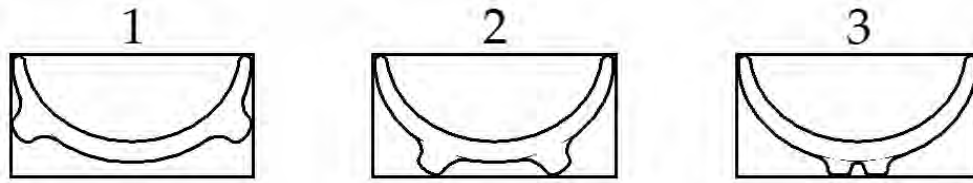

When I am designing one of my walking bowls, I first determine what type of attitude or personality it will take on. Do I want it to be in a crouched defensive position (1), a relaxed or natural position (2), or do I want it to appear as though it has been frightened and is trying to retreat (3)? I've illustrated an example of body type I would make for each stance. The variables are the position of the "hips" on the outer surface of the bowl and the angles of the leg joints. I've illustrated each example based on the 6x6x3 bowl blank, but if the proportions of the blank change, so should the plotting of the hips on the body.

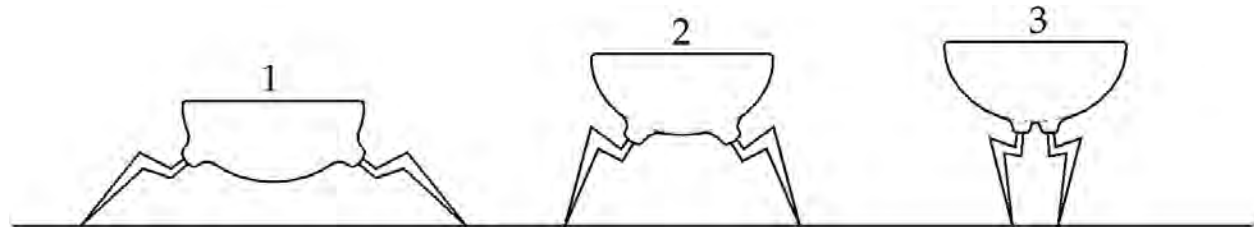

I personally like the look of the middle example (2) and it's the easiest one to put on a chuck and eventually carve, so that's the one I'll use for this demo.

Turning the outside of the bowl

Because I need full access to the bottom of the bowl when turning, I like to put the bowl blank on a faceplate or worm screw. This makes it much easier to turn the full shape of the outside of the bowl, in addition to creating a recess for the chuck for when it comes time to hollow the bowl.

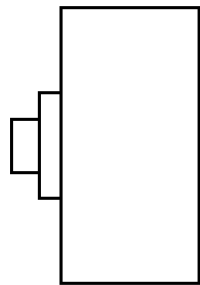

I typically save myself some time by cutting my blanks round before putting them on the lathe, but if you're into beating yourself up, I guess you could spend a while knocking off the corners. Once you've finished that, it's time to start shaping the outside of the bowl. The most important thing to remember is NOT to turn away the hips, which is essentially an oversized foot on the bowl.

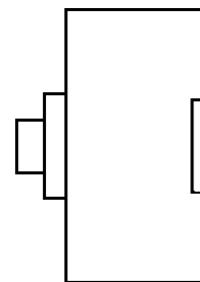

Turn a recess at bottom that will fit your chuck jaws. It's never fun to finish the outer form, take the faceplate off, try to chuck the piece and then realize the recess is either too big or too small.

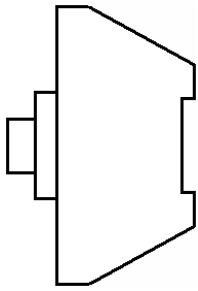

Turn away any excess material while continuing to work your way closer to the finished form.

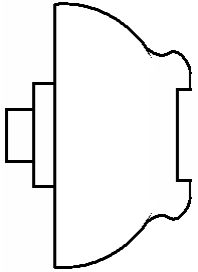

This form is the goal for the outside of the bowl. Ideally, you'll have an attractive curve to the bowl, a recess for the chuck that doesn't go so deep as to interfere with the continuous curve of the bowl, and an oversized foot that can later be carved into three individual hips. Be mindful that the foot should have enough "meat" so that you can later carve away the excess material between the hips to blend the sides of the bowl into the bottom in a continuous curve.

Turning the inside of the bowl

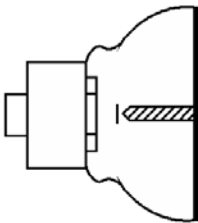

Save yourself some more time by using a Jacobs chuck to drill a depth hole. Make sure you mark the depth on the drill bit before starting the hole, so you don't drill past the preferred depth (just shy of the finished interior bowl depth).

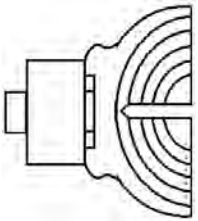

Because I usually turn dry wood, I don't have to worry about keeping the center of the bowl intact until the end, so I like the start close to the center and make a series of small cuts increasing the size of the bowl interior with each pass.

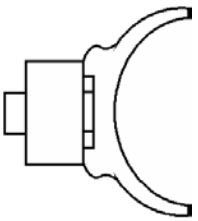

Before you start your final passes of the bowl interior, keep in mind that leaving the bottom of the bowl thicker than the sides is recommended. This provides excess material to support drilling into the hips, carving the excess foot, and any tension that the legs will put on the bowl after assembly.

Plotting and carving the hips

Before you decide on the hip placement, you need to first understand which portion of the foot should be considered waste material and which areas are usable for hip placement and design experimentation.

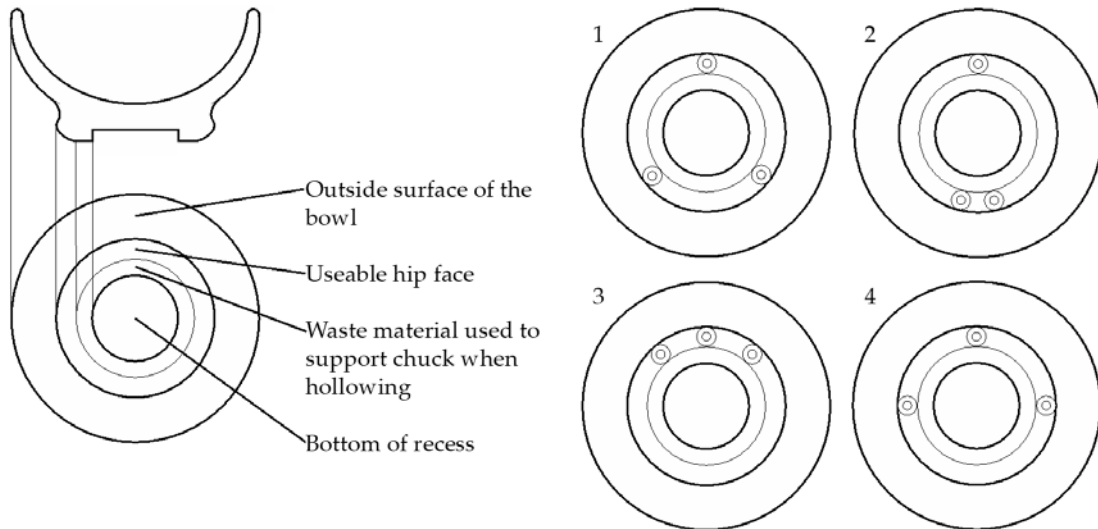

Planning for hip placement

When planning the hip placement, you must again consider the stance of the piece. Do you want a balanced stance where the legs are spaced evenly from each other, as demonstrated by example 1? Or do you prefer a stance with the legs all weighted toward one side, as in example 3?

Examples 2, 3 and 4 each have their own challenges accompanying the stance, mostly due to balancing the piece. I've found that examples 1 and 2 have the highest success rate, both visually and structurally.

Drilling the holes for the legs

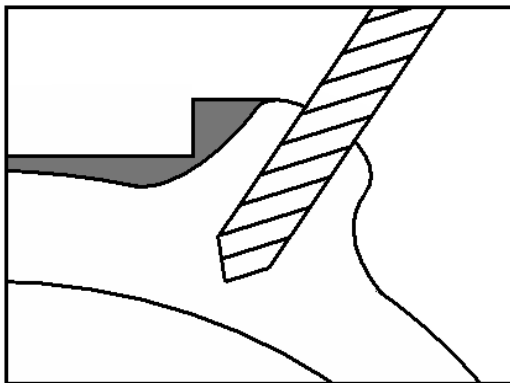

Drill the holes before carving away the excess foot around each hip. This leaves enough support material around the socket that it will be less likely to “break a hip” while drilling the hole.

I typically use a drill bit about 1/3 to 1/2 of the width of the useable hip face and drill perpendicular to the bowl, which should make the hole parallel with the angle of the hip. Using calipers, make sure to measure the thickness of your material from the hip face to the interior of the bowl, then mark the drill bit to drill to

depth. I would recommend setting your depth just shy of the inside of the bowl. That way you won't drill through the inside of the bowl, but will give yourself enough surface material to hold the legs securely.

Carving away excess material to create the hips

There are two areas that you will need to carve to create hips with a smooth transition from the main body to the socket where the legs are inserted.

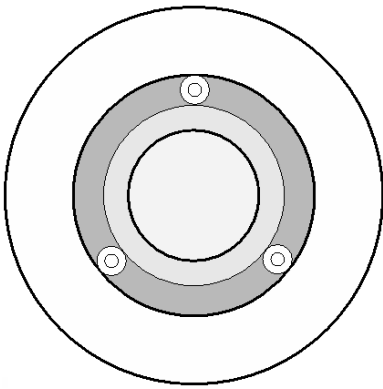

The first area to focus on while carving is the space between each hip. The trick to removing this area and making it appear as though there was never a full foot there in the first place is by making sure you pay attention to the profile of the bowl. This can be difficult, because you have to visualize the bowl as though the foot were not there. A lot of the technique is in feeling that the curve is continuous after you remove the foot.

Continue carving until the space between the hips is indistinguishable from the bowl. While carving, make sure the sides transition smoothly into the bottom with no interruption.

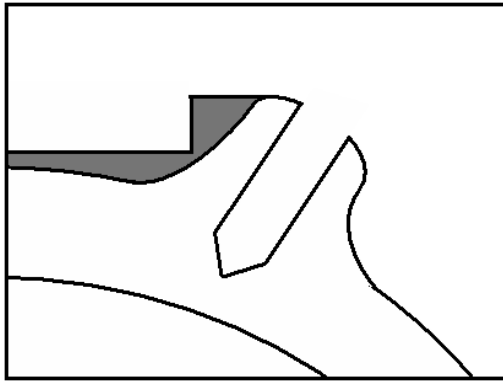

The second area to spend some time on will be inside the hips where there is still a hard angle from the recess that was created for the chuck. The goal here is to remove the angle and to create the gentle curve from the face of the hip to the bottom of the bowl. Because there should only be a small section of this left over inside each hip from the initial removal of the foot, this shouldn't take too much time. When carving, make sure you don't remove too much material from the hips and be sure to remove all of that hard line.

Turning the legs

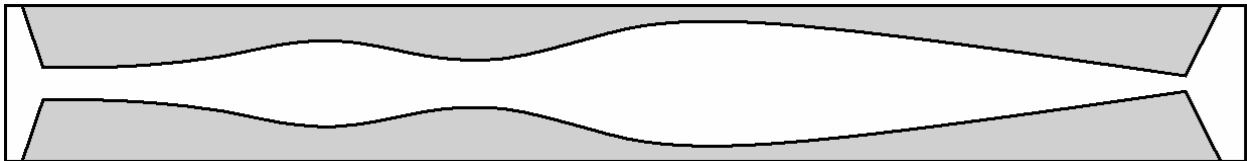

I typically design this simple style of turned leg in three sections: the section that connects to the body and angles down; the next section which angles back up; and the last section, which is oftentimes the longest, angles back down to touch the floor. Unless the leg is excessively long, all three sections can be easily turned from one spindle blank, as seen above.

If I imagine a creature's leg, I picture curved lines. There are no straight lines in nature, which is why you'll see so many curving lines in the legs and bodies of my walking bowls and other creations. The shallow coves gradually transitioning to beads create a more graceful leg than straight lines and hard angles.

Begin turning the leg by putting the spindle between centers and turning your square blank into a cylinder. Then mark where you want the joints or "knuckles". These need to be thicker than the transitions between the knuckles for the joint to rotate and match back up again properly.

Once the knuckles have been marked, turn the leg into the curvy lady form seen above.

Cutting, rotating, and reassembling the legs

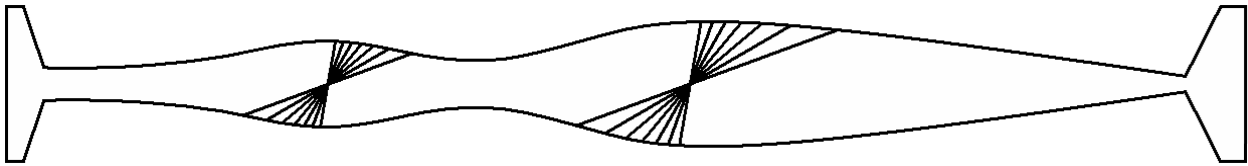

There are a few things to consider when determining the angles at which you cut the legs. The first consideration is where the hips are placed on the bowl. This is important because it determines the angle at which the legs enter the body. The second consideration should be how tall and how wide you want the stance to be. Every angle affects the overall appearance of the finished piece. Below is an example of a turned leg with possible cut lines for each joint. For demonstration, these angles range from 80° to 20°.

Because you must rotate each section 180° to achieve the desired angle, cutting the sections at 90° would do nothing but spin the sections on their axes when rotated. Additionally, the further we get from a 90° cut line, the more extreme the joint angle will be after rotation.

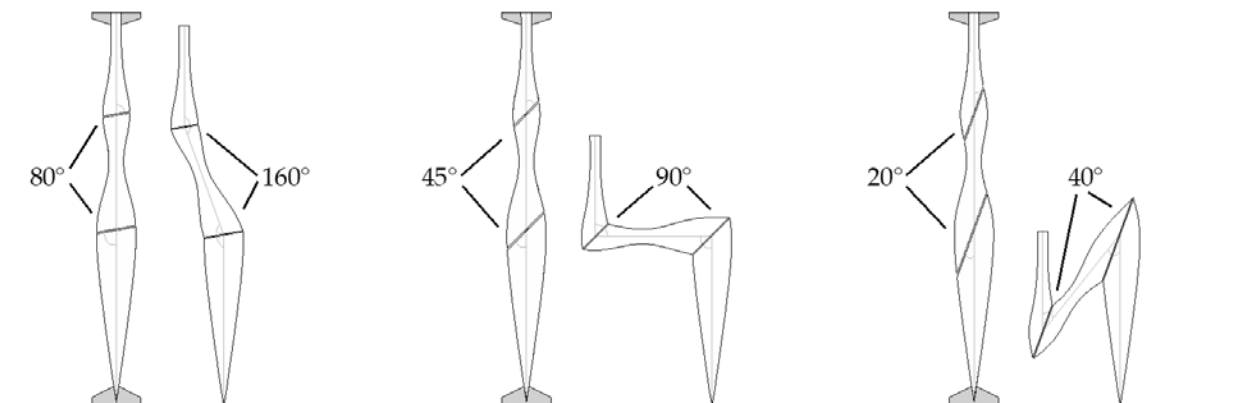

Once you've determined the joint angle and cut on the line you've established, lightly sand the newly cut faces. Try not to sand so much that you change the angle; the leg sections just have to meet without gaps once rotated. Glue the pieces together with two-part epoxy and let set up. Once the first glue-up is set, you need to cut the groove for the spline. I use a dovetail saw, which gives me just enough space in the kerf for more two-part epoxy and one piece of 1/64th inch veneer.

Splines and Assembly

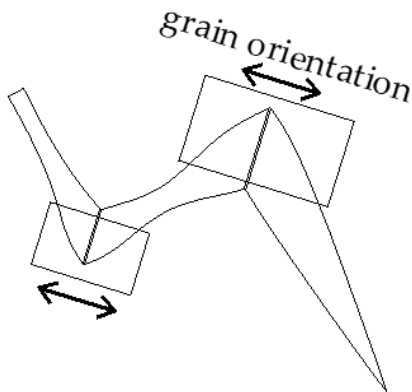

For the best support, make sure you glue the veneer spline in place with the grain running perpendicular to the joint.

Once the second glue-up has set, cut or break away excess veneer, clean up any excess glue, sand the legs and body thoroughly, then assemble the legs and body into one piece.

Ta Da! Yay! Go you!

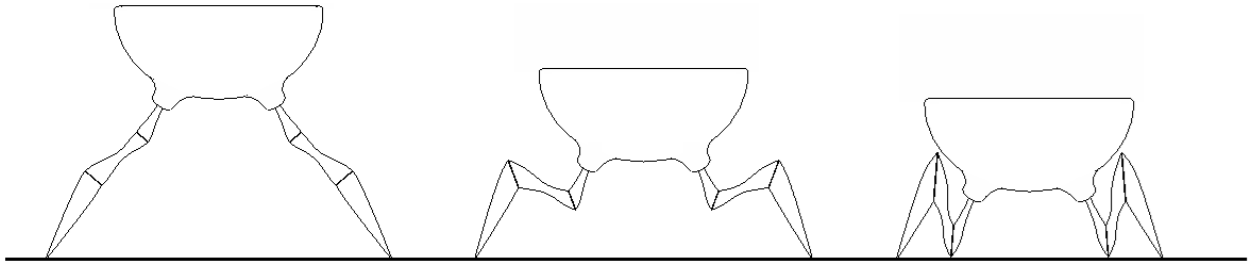



[<Link to List of Demonstrations>](#)

Tips & Tricks for Perfection in Pens

Initial Work Tips

Selecting Materials

Material Utilization

Marking Materials

Cutting/drilling Materials

Prepping Materials

Gluing tubes

Inserting

Facing

Tips and Tricks Topics

Tools

Mandrels

Mandrel abuse

Pin chucks

Cutting tools

Sharpening

Bushings

Lack of bushings

Measuring devices

Perfection fit techniques

Design and trim to fit

Disassembly techniques

Turning to dimension

Press to fit

Quality ink fills

Kit adaptations

Losing the center band

Making special parts

Lengthening/shortening)

Kit-less pens

Stick pens

Nibs

End caps

Closed end pens

Single piece pens

After turning enhancements

- Pyrography

- Painting

- Engraving

- Inlaying

Materials Tips

Wood glue ups

- Oily woods

- Adhesives

Stabilized woods

- Processes

- Equipment

- Technique

Metals

- Selection

- Tools

- Speeds and feeds

Solid surface materials

- Corian

- Corian look a-likes

Antler/bone

- Stabilizing

- CA fill

Polymer Clay

- Selection

- Process

- Firing

Casting

- Forms

- Materials

- Vacuum

Finishing Tips

Sanding techniques

- Traditional grits

- Micro mesh

- Other abrasives

Friction finishes

CA finishes

Lacquers

Pen Discussion & Interaction Groups

Pen Makers Guild (<http://penmakersguild.com/>)

International Association of Penmakers (<http://www.penturners.org/forum/portal.asp>)

Material Source lists

Arizona Silhouette (<http://www.arizonasilhouette.com/>)

Beall Tool (<http://www.bealltool.com/>)

Bear Tooth Woods (<http://www.beartoothwoods.com/>)

Berea Hardwoods (<http://www.bereahardwoods.com/new/>)

Bethlehem Olive Woods (<http://www.bethlehemolivewood.net/>)

BG Artforms (<http://www.bgartforms.com/>)

Craft Supplies USA (<http://www.woodturnerscatalog.com/>)

HUT Products (<http://hutproducts.com/>)

Kallenshaan Woods (<http://www.kallenshaanwoods.com/servlet/StoreFront>)

Klingspor (<http://www.woodworkingshop.com/>)

Penn State Industries (<https://www.pennstateind.com>)

Rockler (<http://www.rockler.com/>)

River Ridge Products (<http://www.rrpwhite.com/>)

Turchetta Supplies (<http://www.turchetta.com/goldennib/home.htm>)

Woodcraft (<http://www.woodcraft.com/>)

Woodchuckers (<http://www.woodchuckers.com/>)

Woodturningz (<http://www.woodturningz.com/SlimlinePenKits.aspx>)

Additional references

Turning Pens and Pencils by Kip Christensen, Rex Burningham, and Dale Nish

Linden Publishing Pen Turner's Bible by Richard Kleinhenz

Fox Chapel Pen Turners Workbook, 3rd edition by Barry Gross

Schiffer Publishing Turning Modified Slimline Pens Beyond the Basics by Don Ward

Learning Turning – Turning Pens w/ Kip & Rex: The Basics and Beyond, Volumes 1 & 2

The Pen Turner's Workbook: Making Pens from Simple to Stunning by Barry Gross

Pens from the Wood Lathe: Step-By-Step Instructions for the Wood Turner by Dick Sing



TURNING 28

WITH KURT HERTZOG

[<Link to List of Demonstrations>](#)

Taking Pen Presentation to the Next Level

Presentation Materials Purpose

Pen type

Kit

Custom

Sales aid

Display

Security

Sales/delivery packaging

Delivery only (disposable)

Protection while shipping

Presentation event (ongoing use?)

Owner display

Collection display

Daily use

Private environment

Public environment

Sales Aid

Plastic stands

Commercial displays – boxes/stands

Custom crafted displays

Sales/Delivery Packaging

Velour bag

Plastic sleeve

Card board enclosure

Cost

Delivery only

As above

Mailing container

Tissue paper

Custom box

Cost

Presentation

Custom and unique – one-time event

Ongoing use

Convenience

Cost

Durability

Exposure

Publicity

Owner Display

Collection display vs individual

Location for display

Secure?

Daily Use

Esthetics

Exposure

Publicity

Cost

Collection Display

Compatibility with other items

Yours is the base or added in

Secure?

Esthetics

Cost

Transportability

Durability

Exposure

Daily Use

Location

Convenience

Esthetics

Cost

Attitude

Security

Durability

Public location

Private location

Creating Presentation Opportunities

Adaptation of existing products

 Laser engraving

 Artistic alteration – painting, piercing, pyrography, inlay, engraving, etc.

 Materials

Time frame constraints
 Special collaboration
 Cost
 One off?

Creation of Unique Product

Material
 Time available
 Processes available for access and compatibility
 Personalization
 Cost
 Adornment techniques
 Durability

Examples & thought starters

Pen Discussion & Interaction Groups

Pen Makers Guild (<http://penmakersguild.com/>)

International Association of Penmakers (<http://www.penturners.org/forum/portal.asp>)

Material Source Lists

Arizona Silhouette (<http://www.arizonasilhouette.com/>)

Beall Tool (<http://www.bealltool.com/>)

Bear Tooth Woods (<http://www.beartoothwoods.com/>)

Berea Hardwoods (<http://www.bereahardwoods.com/new/>)

Bethlehem Olive Woods (<http://www.bethlehemolivewood.net/>)

BG Artforms (<http://www.bgartforms.com/>)

Craft Supplies USA (<http://www.woodturnerscatalog.com/>)

HUT Products (<http://hutproducts.com/>)

Kallenshaan Woods (<http://www.kallenshaanwoods.com/servlet/StoreFront>)

Klingspor (<http://www.woodworkingshop.com/>)

Penn State Industries (<https://www.pennstateind.com>)

Rockler (<http://www.rockler.com/>)

River Ridge Products (<http://www.rrpwhite.com/>)

Turchetta Supplies (<http://www.turchetta.com/goldennib/home.htm>)

Woodcraft (<http://www.woodcraft.com/>)

Woodchuckers (<http://www.woodchuckers.com/>)

Woodturningz (<http://www.woodturningz.com/SlimlinePenKits.aspx>)

Additional references

Turning Pens And Pencils by Kip Christensen, Rex Burningham, and Dale Nish

Linden Publishing Pen Turner's Bible by Richard Kleinhenz

Fox Chapel Pen Turners Workbook, 3rd edition by Barry Gross

Schiffer Publishing Turning Modified Slimline Pens Beyond the Basics by Don Ward

Learning Turning – Turning Pens w/ Kip & Rex: The Basics and Beyond, Volumes 1 & 2

The Pen Turner's Workbook: Making Pens from Simple to Stunning by Barry Gross

Pens from the Wood Lathe: Step-By-Step Instructions for the Wood Turner by Dick Sing



TURNING 28

WITH CARL JACOBSON

[<Link to List of Demonstrations>](#)

Embellishing with Milliput

We'll inlay Milliput in a turned piece. Milliput is a two part epoxy putty that can be molded and shaped. It comes in a variety of colors and can be mixed together to create patterns or stand along. I'll make a small recess in the turned piece and inlay the Milliput in to decorate it.



TURNING 28

WITH CARL JACOBSON

[<Link to List of Demonstrations>](#)

Making Your Own Natural Void

We'll make a small hollow vessel and cut our own void in the side to replicate a natural void. I'll cut into the side before hollowing it, and then reshape the holes to create a natural looking void. After the void is shaped I use a small torch to burn the edges to make the look like a natural void.



[<Link to List of Demonstrations>](#)

Are You With Me?



"...Your unit has been around a while now and there are lots of "new" ideas out there but you can quote me on saying don't mess with what works...and your unit works! Thanks Lyle!"

Wilford from Alabama 9/11/12

The above quote got me thinking, not so much about my hollowing system that he is referring to, but the process I have developed. Do you turn without catches? Do you start between centers? Do you start on the balance point? Do you turn fast? Do you have the drive center with the adjustable pin? Do you use faceplates? Do you ALWAYS take advantage of grain direction? Do you do the outside of hollow forms in stages? Do you do the inside of bowls in stages? Are you using sharp, I mean really sharp tools? Do you use sharp sandpaper? Do you turn without vibration? Do you use bevel support? Do you plan ahead or just wing it? Do you use the band saw safely (read-not at all)? Do you finish the finish? Do you friction drive reverse turn? Do you do the outside and inside of a bowl on the same axis? Do you exceed the safe limits of your tools?

I have learned techniques from the best turners in the world in the 90's by taking individual classes. In the last 10 years or so I have seen about every big name turner in the world do their thing first hand as I travel around the USA doing symposiums as a vendor and demonstrator. I have taken the best techniques and processes from all these experts and put them together into one process. There are many different methods but none that work as well as mine, not right or wrong. In my DVD I explain WHY I do what I do. The bottom line is I have a process that prevents problems, is safety minded, steers clear of obstacles and has the least amount of limitations possible.

My method is not mine but a compilation of the best way to do things molded together into an efficient process. Yet, I see my students using chucks or screw chucks or steady rests, or dull tools, or spindle roughing gouges, etc. etc. etc. So, if what I have developed works so well, why

doesn't everyone that is exposed to it, use it 100 percent of the time? I think some just see a new method and say to themselves, "That's nice, but my way works for me, don't try to teach an old dog new tricks." Sometimes I think some have to justify the fact they have spent a lot of money on tools that don't work very well. It is a shame to have a multi-million dollar quarterback who sits on the bench, but we have to play with the guy that can get the ball down the field. My process is the easiest, easy on my body, easy on the wood, easy on the lathe, requires less sanding, easy on the tools. My process puts you in complete control, the control means you are working safe, with no fear and no catches, so you have more fun and with more fun the creativity can get to levels you never could imagine.

What happens if you don't take the whole package? You only get part of the picture. The part of the process you decide to ignore will result sooner or later in an obstacle or limitation. Our tendency is to push the envelope as far as we can. We want to turn bigger, thinner, taller, faster, stronger, whatever. So the limitation will likely crop up sooner, rather than later. How do you resolve the obstacle? You need to put a band aide on the problem. You find a way around it. You find a fix. The band aide becomes an obstacle in itself and a domino effect starts to complicate things...unintended consequences.

My process prevents the obstacle from getting in the way of your accessibility or creativity rather than trying to fix the problem, after it exists. It only makes sense to eliminate the possibility of problems and not have to find a fix. So many of the conflicting portions of what many others demonstrate these days are due to the teacher showing you how to fix a problem. The instructor has good intentions usually and is not just trying to sell you more tools you don't need, but isn't it a better path to not have the problem in the first place?



[<Link to List of Demonstrations>](#)

Sunburst Bowl



The first time I made this bowl its coloring and embellishments suggested a sunburst to me. Now, no matter what color or how I finish it I still call the design a Sunburst Bowl. This bowl is intended to be a canvas, so to speak, for coloring and other embellishment. It's wide, showy rim presents all sorts of opportunities for creativity. I'll step you through the process of turning the bowl, and then show you one approach for embellishment.

Sunburst style bowl – this one named “Moonglow”

I used 12 inch x 12 inch x 3 inch thick kiln dried mahogany. Size is not critical; larger or smaller is OK.

If you start with a wet log, you'll have to go through a process of rough turning (turning to the approximate final shape, but leaving the bowl about an inch thick), drying the rough turning, then re-turning the dry bowl to final dimensions. Using wet wood is beyond the scope of this article, so I'll start with my kiln dried board.

Mark the center (Photo 1) and cut off the corners.

Mount the board on the lathe between centers or in a screw chuck and true up the blank - rounding it and flattening the sides (Photo 2). Be careful about lathe speed. The blank is out of balance during the truing process, requiring you to use a much lower speed than you might like. As the blank comes into balance you can increase the speed. I found that my board apparently had variations in density within it which made it inherently out of balance even when trued up. Because of this I was never able to run the lathe speed as high as I would have liked.



Photo 1 - Center marked



Photo 2 – Bowl blank mounted on a screw chuck and trued

After truing, mark a tenon diameter on the blank. For my chuck 2.5 to 3 inches is good (Photo 3).

Cut a tenon about a quarter inch deep (Photo 4). Leave it a straight sided for now. If you use dovetail type chuck jaws, we'll cut the proper profile later.



Photo 3 - Tenon marked



Photo 4 - 1/4 inch tenon cut

Now mark the bowl's base diameter about 3/4 inch larger than the tenon (that is, 3/8 inch out from the tenon) and cut the base with a straight side about 3/8 inch deep (Photo 5 and 6).



Photo 5 - Base diameter established

Shape the underside of the bowl using a bowl gouge. The intended shape is a gentle curve upward (Photo 8 and 9).

At this point, if you use dovetail profile chuck jaws, cut the side of the tenon to a dovetail profile (Photo 7).

Shape the base as a simple bead using a spindle or detail gouge (Photo 7).



Photo 6 - Close up of base and tenon before shaping

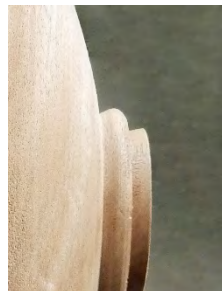

Photo 7- Close up of base and tenon after shaping



Photo 8 - profile of bowl bottom, base, and tenon

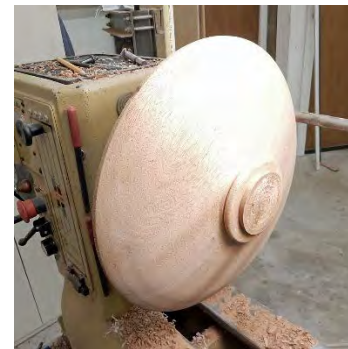

Photo 9 - Curve of underside of bowl

Power sand the bottom. I use 80 grit, then 120, then 220.

Reverse the bowl by putting the tenon previously cut in a 4-jaw (scroll) chuck (Photo 10).



Photo 10 – Bowl reversed

Decide how big you want the bowl (inner depression) to be. The size is a personal aesthetic choice. I like a fairly wide rim, because the rim is an opportunity to present an eye-catching design. For this example, I decided to make the bowl a little smaller than half the outside diameter, about 5 inches. Mark the bowl diameter on the wood (Photo 11).



Photo 11 – Central bowl marked

Shape the gently conical rim, then remove excess wood from the central area, but do not cut the central bowl yet (Photo 12). A cross-section of the bowl design is shown in Drawing 1.



Central wood removed



Drawing 1 – Sunburst Bowl cross section

Sand the rim through the grits to 220 grit.

With a parting tool turn a recess at the edge of the inner bowl to define the diameter of the bowl (Photo 13). Now, using a bowl gouge, shape the inner bowl, followed by some light passes with a negative rake scraper to smooth out any remaining tool marks (Photo 14). Sand through the grits to 220 grit.



Photo 13 - Recess cut with parting tool at outer edge of depression



Photo 14 - Inner depression completed

The outer 3/4 inches of the rim is going to be gilded (application of metal leaf). To make a transition from the gilded area to the non-gilded region I cut a shallow groove (Photo 16). I used a very narrow parting tool that I made from an old stainless steel butter knife purchased at a resale shop for twenty cents (Photos 15 a & b).



Photo 15a – Very thin parting tool made from a butter knife



Photo 15b – Thin parting tool detail



Photo 16 – Thin, shallow groove cut with butter knife parting tool

Embellishment

I'm going to go through the process I used to embellish this example, but I would like to encourage you to use your own creativity and ideas. Maybe make the first one like mine to learn the process, but for your next one, come up with a new approach. Get out your carving tools or wood burner. Dig around in the art store for interesting colors and materials to try.

The paints and gilding supplies described here are available from art supply stores. If you can't find what you need locally, everything can be ordered from on line stores such as dickblick.com, or Google "gilding supplies" and "Lumiere paints" for other sources.

The next step is to do some prep work for gilding.

Remove the bowl from the lathe (leave it in the chuck) and clean off any fine sawdust on the wood using a tack cloth or air gun. Apply your favorite clear finish. I sprayed on two coats of Deft gloss brushing lacquer (no thinner) using an inexpensive detail spray gun (Photo 17).

Steel wool the lacquer lightly with 0000 wool if needed. Remove any steel wool dust.



Photo 17 – Two coats of lacquer on the bowl

Apply flat black paint to the bowl. As it turned out the "flat black" latex that I used was not so flat; it had a light sheen which I think looked better than had it been dead flat. After the black paint dries, sand the raised grain lightly with 400 grit sandpaper. Then apply a second coat of black.

After the second coat dries stipple Lumiere 520 Pearlescent Blue on the black paint. Stipple: The paint is applied with a "dry" brush pressed on the work piece leaving a feathery pattern. To get the brush to that "nearly dry" state, first load the brush with paint then, on scrap paper press the brush straight down repeatedly until you get the feathery pattern you like (Photo 18). Practice on a scrap sheet of black cardboard (I painted a sheet with my flat black latex - Photo 19). Now stipple the pearlescent blue paint on the black surface of the bowl (Photo 20). Since

the brush is nearly dry, you may have to reload it with paint and repeat the process until you are satisfied with the pattern on the bowl. To add a bit of subtle interest to the pattern I cleaned the brush with water, then stippled Lumiere 576 Hi Lite Blue in the central area of the bottom of the bowl.



Photo 18 – Dry brush technique

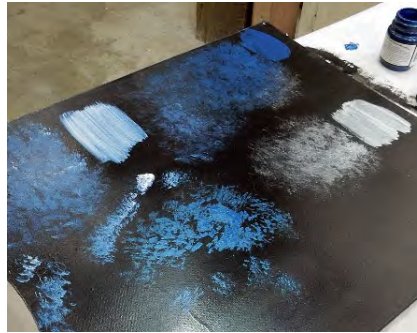

Photo 19 – Dry brush practice

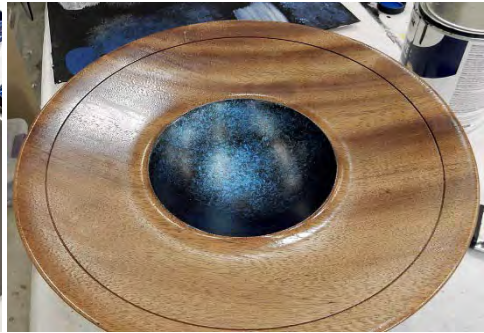

Photo 20 – dry brush stippling applied to bowl

Gilding

Gilding is a pretty easy process. For this project I'd suggest you use imitation gold leaf (or for that matter, any color leaf that appeals to you). Although the application methods are similar, real gold leaf is considerably more expensive than the imitation stuff, and trickier to apply. The imitation leaf looks quite good. I used variegated (imitation) gold leaf. In addition to the leaf, you'll need gilding size (the adhesive for the leaf). Gilding size is available as either solvent or water based. Either works fine, but water based seems easier to come by.

- Paint the gilding size where you want the leaf to stick (Photo 21, 22, & 23).



Photo 21 – Painting gilding size

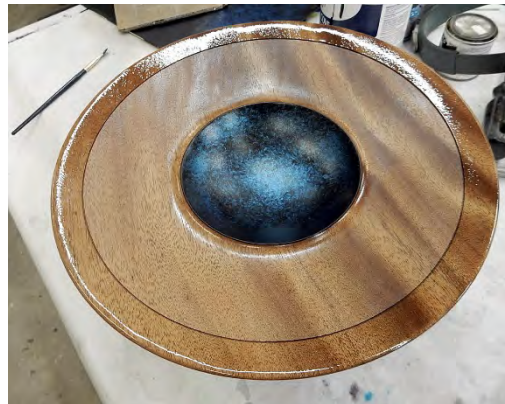

Photo 22 – Gilding size painted all around rim



Photo 23 – Mona Lisa water based gilding adhesive

- The instructions for the size should tell you about how long to wait before applying the leaf. In any case, you can apply the leaf when the size becomes sticky. For the size I used, that's about an hour after application. If you wait too long, just paint on more size and allow it to become sticky again.
- Cut up the leaf with scissors into pieces about 2.5 inches x 1.5 inch (Photo 24).
- Carefully lay the leaf on the areas where you've applied size. Press it down with a soft dry brush (Photos 24 and 25).
- Lay the next piece so that it overlaps the previous piece. Press it down with the brush. Neatness is not a virtue here: there will be excess leaf hanging out all over (Photo 26).



Photo 24 – Laying first piece of metal leaf



Photo 25 – Pressing leaf down with brush

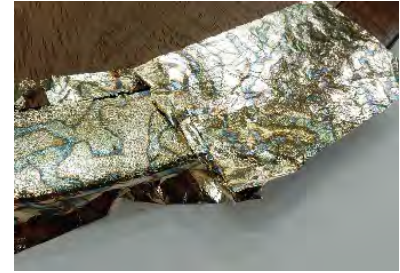

Photo 26 – Laying second piece of leaf

- If you miss a spot, just tear off a piece of excess leaf and press it down where needed.
- Continue all the way around the rim.
- Go around the rim again with the soft brush, pressing the leaf down into the size. Then gently press the leaf down again with the palm of your hand.
- Use the brush to “sweep” all the excess leaf off.
- Small fragments of leaf will end up on the rim and in the central bowl where you don’t want them. Use a bit of masking tape to pick the fragments off.
- The narrow recess between the gilded and non-gilded areas may get leaf in it. Use your butter knife parting tool to scrape it out (off the lathe).

After gilding, apply more coats of finish, avoiding getting finish on the central part of the bowl. I sprayed on two coats of lacquer.

When the finish is dry, remount the turning on the lathe. With a wide Sharpie marker steadied on the tool rest, rotate the bowl by hand while pressing the marker on the bowl’s outer rim to make a crisp black stripe around the bowl (Photo 27). Thanks go to Jimmy Clewes for showing me how to do this. Do the same at the transition between the rim and the edge of the bowl (Photo 28).

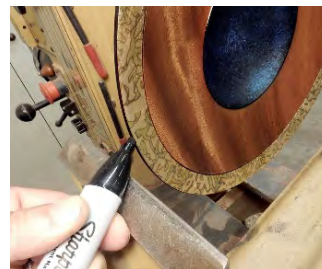

Photo 27 – Sharpie stripe around rim



Photo 28 – Stripe on edge of bowl



Photo 29 – Bowl reversed in Jumbo Jaws

Now it’s time to complete the foot. Remove the bowl from the chuck. Reverse it in Jumbo Jaws (Cole Jaws), a vacuum chuck, or use some other method to reverse the turning (Photo 29).

Turn off the tenon (Photo 30). Shape the foot (Photo 31). Sand the foot to 220 grit.



Photo 30 – Tenon removed

Remove the bowl from the lathe. Blow off the sawdust and finish the bottom with your favorite finish. As before, I sprayed on lacquer - three coats (Photo 32).



Photo 31 – Foot shaped



Photo 32 – First coat of lacquer applied to bottom of bowl



Photo 33 – Ultra-fine Sharpie to blacken narrow groove

Finally, using an ultra-fine Sharpie, blacken the narrow groove at the edge of the gilding (Photo 33), then steel wool, wax, buff, and admire.

I generally don't make more than one of anything – I lose interest and want to move on to something new. Yet I've made quite a few Sunburst Bowls and plan to make more. Each one is unique; with each I get more and more adventurous with my embellishment techniques. Keep in mind, this isn't really a bowl; it's a canvas for your creativity.





TURNING 28

WITH ALAN LACER

[<Link to List of Demonstrations>](#)

Skew Chisel

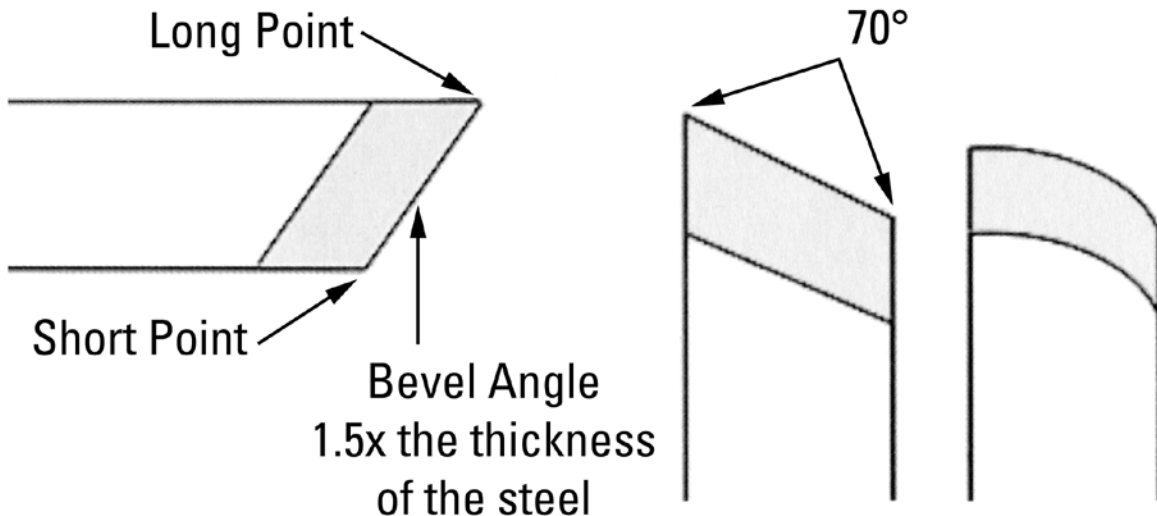

SKEW CHISEL SELECTION

I prefer rectangular sectioned skews, the heavier the better (at least 1/4" thick, better yet, 5/16" or 3/8") with the short point side corners rounded back to the ferrule, the long point side corners chamfered (slight rounding) back to the ferrule. I do not like the oval sectioned skews: they are overly thinned out, rock on the tool rest when grinding, nearly impossible to do the peeling cut (which I use a great deal), and presents a changing angle to the wood as presented in several of the cuts below—such as the rolling cut.

Sizes: I primarily work with two sizes: a smaller one that is 1/2" or 5/8" and a larger one that is 1 1/4" or 1 3/8". These sizes generally work well on all the cuts below on stock 5" in diameter down to miniature sizes.

Preparation: get it sharp through grinding, refine and maintain the edge through hand honing using a diamond hone. Make sure the tool rest is filed flat and clean, wax the top surface of the rest. Drive the work with a ring center rather than a spur—especially if you are in a learning phase.

CUTS

Practice the following cuts on a softer wood like yellow poplar, alder or pine.

Planing: most commonly done with the short point down and leading the cut—but cutting anywhere along the area just above the short point to just above center of tool, handle is positioned at about 45 degrees to the axis of lathe. Problems: skating, dig-in, ribbing, chip-out.

Roughing: using the tool in the same position as the planing cut, the skew can be used to round smaller diameters (usually under 2 1/2") and shorter pieces (generally under 18" in length). It is very much a pushing off of the corners to reach the cylinder. In chippy woods like

red oak or ash, I either use the planning approach but shorten the length of each cut or use a peeling approach—followed by a planning cut to clean the surface.

Peeling: using the skew like a veneer peeler’s action on a log. The cutting edge is held parallel to the lathe’s axis, but with the handle low in back to provide a cutting edge that has bevel support—not a scraping action with just a sharp edge. Place the long point against the side of the wood you intend to keep. I normally use only a portion of the tool’s edge as too heavy of a cut is hard to make or control. This is a sizing and rough cut—not for finishing. It can be used to take the corners off of a square, cut tenons, or remove large amounts of waste material.

Vee: long point down, cutting with an arcing motion. For the first cut, the point is at a right angle to the axis of the lathe. To deepen or widen the “V” that is created, come from the side of the original cut, being sure to clear the long cutting edge away from the area just cut.

Problems: skating, burning, “stalling out.”

Shoulder or Facing-Off: long point is down, long cutting edge is tilted away from the face of the shoulder only a few degrees (2 to 5). Cut is performed high on the work, using an arcing motion and ending above the center axis of the lathe. Problems: skating on entry or at any time on the face of the shoulder, dig-in, “stalling out,” torn grain.

Saucer: done very much like the shoulder cut, except the action is now concave. Since this is cutting somewhat against the grain, don’t take the cut too deeply into the end-grain. Useful in doing the bottom of projects like a goblet, vase, toothpick holder, lidded box, etc. or for cutting rings free on a shaft.

Parting: done with the long point down, a series of vee cuts to part a small work pieces/projects off at the headstock side. Tends to avoid many of the problems of parting tools: cleaner cut on the end-grain and seldom snaps the piece off near the conclusion to create a small hole in the end of the project.

Pommel: the process of turning square elements that transition into round. I prefer to cut these with the long point down—especially square shouldered pommels. Layout the placement of the pommel with a single 90-degree line (using a square or protractor). Cut to the waste side with a Vee cut—then turn away material on the waste side until you reach a cylinder (using either a peeling or planning cut). Make the cut to the line using the same method as for a shoulder cut (for the square shouldered pommel). For a curved pommel, make two 90-degree lines—one for the ending point (meets the rounded area of your project) and one for the starting point of the pommel. I usually go ahead and create a square pommel at the end point. Then in a series of light cuts, add a curving motion to create the curved surface until you reach the line that marks the starting point of the pommel. If a relatively friendly wood, I lead with the long point through the entirety of the cut. If a difficult wood (usually very soft or easily torn on the end grain), I start with the long point in the wood, then raise the handle with my back hand to allow cutting in the area just above the long point.

Rolling: using the skew to produce a convex shape, such as a bead. For small beads (under 3/8” wide or less) I often use the long point. For most beads and other convex shapes of a larger size I make the cut with the short point down. You may cut with the short point in the wood (to assist with keeping the tool against the side of the bead and with a bevel rubbing) or with the area above the short point but not above the center of the tool’s long cutting edge. Problems: skating (creating slashes in the bead), dig-ins (getting the trailing edge/point pulled into the wood), shapes that are not rounded—but were intended to be convex.

Coving: using the skew to produce a concave shape. Usually done with the short point down, moving the tool with a scooping action. Here the curved edged skew certainly performs better. Problems: skating and failure to produce a curved surface in the cove.

Rough-Grain: using the skew as the final tool to work an area of twisted grain, severe chip-out or even a knot. First the area is lightly cut with a roughing gouge, cutting edge at a 90 angle to the lathe's axis, with bevel support. Make the cuts across the difficult area lighter and lighter until almost dust like in their action. Next, be sure the tool rest is almost touching the wood, cutting edge of the skew is held parallel to the lathe's axis, tool handle is horizontal, edge is presented in a scrapping approach with no bevel support. Make very light passes across the difficult area, completing with only the lightest of cuts.

End-Grain Scrape: using the skew for scraping directly across end-grain as found on the rims or bases of such projects as lidded boxes, goblets, toothpick holders, etc. Get the tool extremely sharp by honing, place the tool rest as close to the work as possible, present the tool facing the end-grain area, the tool handle should be horizontal (to present the edge in a scraping approach with no bevel support) and lightly scrape across the area. You should be getting tiny ribbons rising from the edge—if not, you may be tearing the grain.

ALTERNATIVE GRIND

Geometry: 70 degrees from point to point; ground bevel angle (equivalent to bevel length) is expressed as 1.5 x steel thickness; behind the short point's bevel a full round to the end of the blade; behind the long point's bevel a flattened surface but with the corners removed.



Advantages:

1. "Tells" you where to cut for planing and rolling cuts (cut where curved)
2. For planing and rolling cuts gives increased clearance angle for the trailing point and trailing edge
3. Gives between 15% and 20% more cutting edge
4. For peeling cuts is self-limiting
5. For peeling cuts puts the handle at a right angle to the axis of lathe
6. Straight section used for scraping actions
7. Straight section used for finishing cuts on rounded pommels
8. Curved edge works better on "chippy" or figured woods
9. Curved edge has lower impact when planing or rolling, has a progressive entry into the wood, better at shearing the fibers
10. Curved edge works better for concave cuts (a curve fits a curve better)

Disadvantages: Harder to sharpen than a traditional ground skew.

For sharpening two sizes of skews with this grind see Alan on YouTube:

<https://www.youtube.com/watch?v=dmCxDTtoHm6Y&t=19s>

More information at: www.alanlacer.com and www.alanlacer.info



[<Link to List of Demonstrations>](#)

A Vortex Bowl



COMMON DESIGN ERRORS

- Too many thick boards in the blank glue up
- Most well-made pieces will have 60 to 80 laminations in the blank
- The more thin laminations the more dramatic the swirl effect will be
- Board slices from the blank too thick. (no more than 1/8" thick)
- Each layer not rotated enough (I use 3/8")

SOME DESIGN THOUGHTS

- I generally design the blank so each side of center is the same glue up sequence (This is not necessary, just my preference)
- My preference for the bottom is to show the solid base not the solid ring #1
- This type bowl looks much better with a segmented lip of a dark wood
- The more color and thin strips used in the blank the better
- I like to use spectra ply since it adds color and saves cutting and glue-up time

GLUING AND CLAMPING SMALL GROUPS



GLUING AND CLAMPING SMALL GROUPS TOGETHER

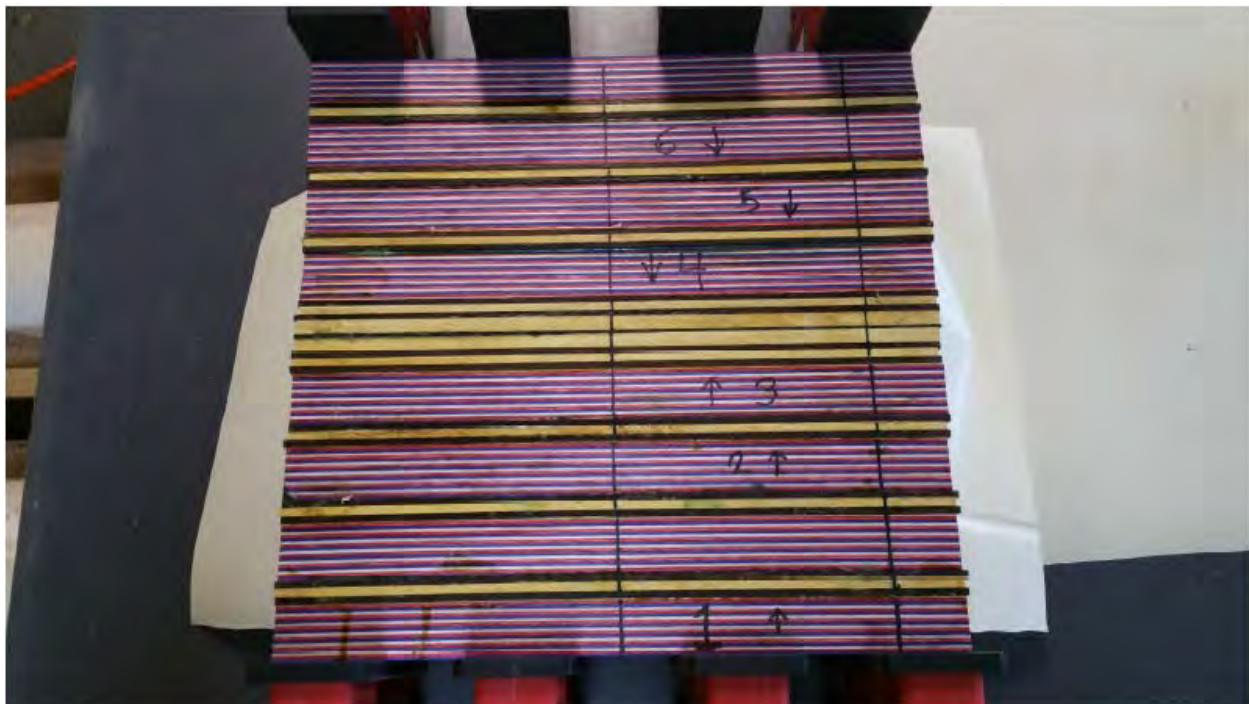

FLAT SURFACING THE BLANK



LAMINATION LAYOUT OF THE BLANK

1" Spectraply-1/8" wenge-5/32" yellowheart-1/4" yellowheart
Center is 1/16 black veneer



SLICING OFF BOARDS 3/16" THICK



SANDING BOARDS TO .125 INCH THICK



RING CUT SHEET

This cut sheet was actually created by Tom Lohman.

It is based on a 12-1/4" diameter bowl consisting of 40 rings 1/8" thick.

In order to get 40 rings 6 boards will be required.

The boards are numbered 1 through 6.

When laying out the rings on the board it is easier to use the OR (Outside Radius) column.

From the cut sheet you can see that board 1 is for Rings 1, 7, 13, 19, 25, 31 and 37.

Ring #	ID	OD	OR	Board #
1	0	2.5	1.25	1
7	2.5	4	2	1
13	4	5.5	2.75	1
19	5.5	7	3.5	1
25	7	8.5	4.25	1
31	8.5	10	5	1
37	10	11.5	5.75	1
2	1.25	2.75	1.375	2
8	2.75	4.25	2.125	2
14	4.25	5.75	2.875	2
20	5.75	7.25	3.625	2
26	7.25	8.75	4.375	2
32	8.75	10.25	5.125	2
38	10.25	11.75	5.875	2
3	1.5	3	1.5	3
9	3	4.5	2.25	3
15	4.5	6	3	3
21	6	7.5	3.75	3
27	7.5	9	4.5	3
33	9	10.5	5.25	3
39	10.5	12	6	3
4	1.75	3.25	1.625	4
10	3.25	4.75	2.375	4
16	4.75	6.25	3.125	4
22	6.25	7.75	3.875	4
28	7.75	9.25	4.625	4
34	9.25	10.75	5.375	4
40	10.75	12.25	6.125	4
5	2	3.5	1.75	5
11	3.5	5	2.5	5
17	5	6.5	3.25	5
23	6.5	8	4	5
29	8	9.5	4.75	5
35	9.5	11	5.5	5
6	2.25	3.75	1.875	6
12	3.75	5.25	2.625	6
18	5.25	6.75	3.375	6
24	6.75	8.25	4.125	6
30	8.25	9.75	4.875	6
36	9.75	11.25	5.625	6

LAYOUT RING DIAMETERS

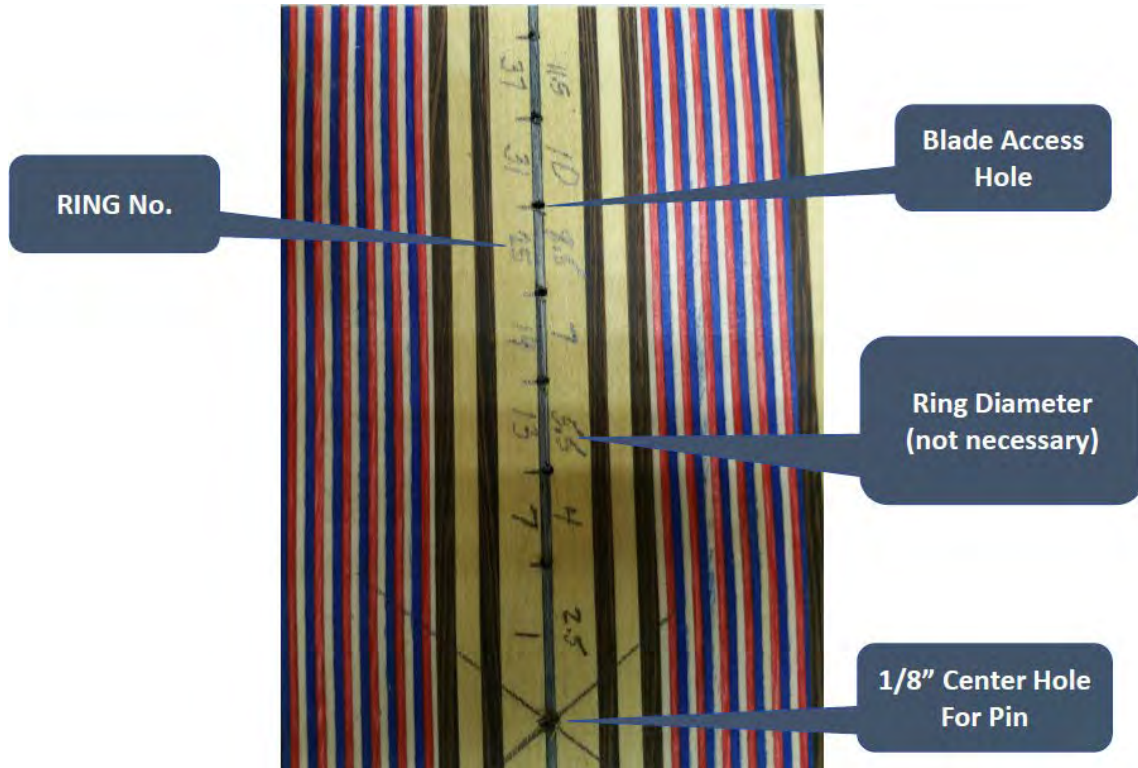

LAYOUT RING DIAMETERS

- Find the center of the board and mark the point with an awl.
- Using a ruler mark the radii (one half of the diameter) of each ring with an awl.
- This only has to be done on one side of center. There is no need to use a compass to draw circles.
- Drill a 1/8" hole in the center to accommodate the pin.
- Drill small blade access holes for each ring.
- Be certain to number each ring.
- Starting with the largest ring insert the scroll saw blade through the access hole.
- Insert the pin through the center hole of the board and into the appropriate diameter hole of the jig.

CUTTING RINGS ON SCROLL SAW

- Cut rings from outside in
- Use spiral scroll saw blade to prevent blade drift

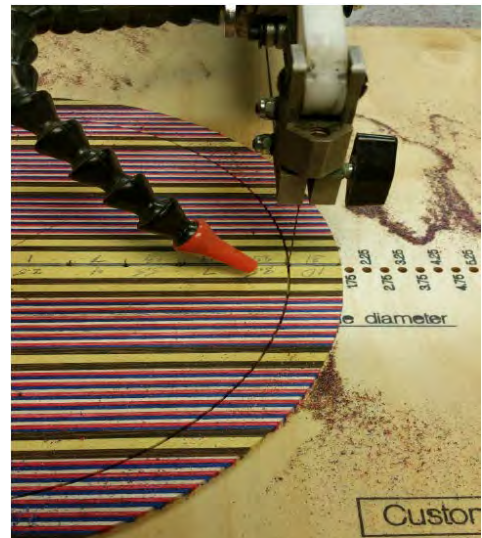
**CUTTING RINGS ON SCROLL SAW**

Blade is inserted through the access hole and the pin is inserted in the center hole and the appropriate diameter hole of the jig.



STACKING AND GLUING RINGS



Ring 14 and 15 are aligned

OFFSETTING RING

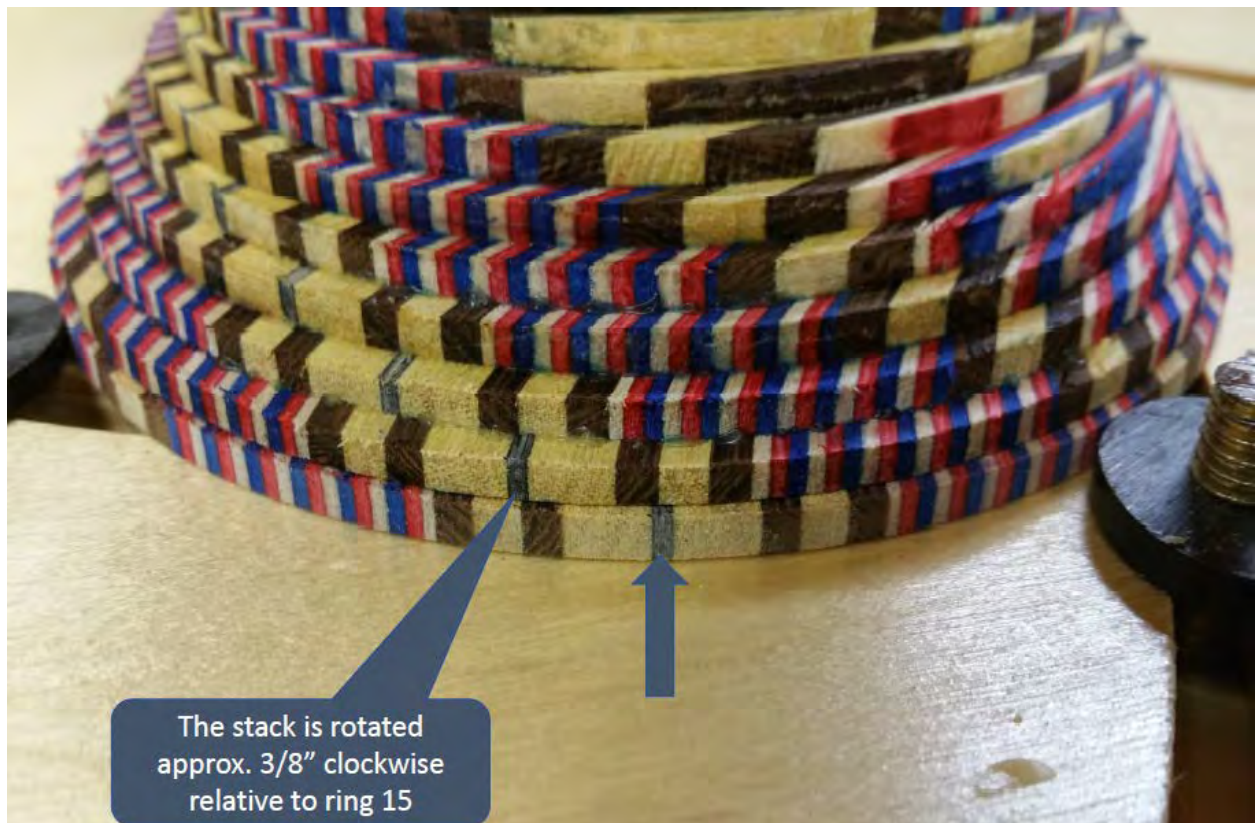

The stack is rotated approx. 3/8" clockwise relative to ring 15

SOME TURNING & FINISHING TIPS

- I prefer a sharp 1/2" bowl gouge
- Sharp tools and lite cuts are a necessity since any type plywood is notorious for chip out
- Spectra Ply dyes will bleed out while gluing but it will be removed when turned
- Final cuts are done with negative rake scrapers
- Sand away any pits left by chip out
- Be sure to remove all sanding dust prior to finishing
- Before finish is applied spray several coats of shellac as a sealer to prevent color bleed
- These bowls look better with a high build high gloss finish – I prefer:
 - MINWAX wipe on poly
 - Spray Lacquer
 - General Finishes Wood Turners Finish
- After curing for a week I wet sand with all grits of MicroMesh



[<Link to List of Demonstrations>](#)

Inlay Kit Assembly

BREAKING PIECES FOR A BETTER FIT

Several of our kits require a piece to be broken for it to fit right. If these inlays were done on a flat surface, the most intricate shape would easily fit in one piece. Because all of our inlays are cut around a cylinder the fit is a whole different story. All of the inlays are mounted on a mandrel and laser cut while the mandrel is rotating which results in pieces with cuts that are tapered toward the center of the barrel (see picture of Texas flag star). One of the consequences of this is that you're trying to fit the inside diameter of the piece to the outside diameter of the barrel. This results in pieces that look like they're way too small to fit in the background barrel of the inlay. In some cases a piece will have to be broken at specific location for a good fit. As long as the piece being broken is dark (black or blue dyed Basswood), the seam will not be visible. (See example of instruction sheet with drawing showing break line.)

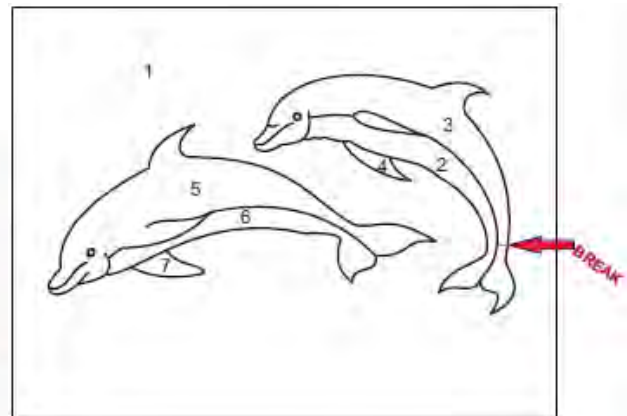

GLUING INLAY PIECES USING A BRUSH TO APPLY THIN CA

When you're assembling the pieces from your inlay kit, in most cases you're going to want to glue them together as you go. (Giraffe kit demonstrates this.) We include small elastic bands to wrap around the barrel so the smaller pieces won't fall out while you're inserting others. This is done with the brass tube from the pen kit positioned inside the barrel but not glued in. Once you've got a few of the pieces in place you will carefully slide out the brass tube (the instruction sheet will tell you when) and using a disposable artists brush apply thin cyanoacrylate glue to the seams of the pieces already in place followed by a shot of aerosol activator.

We used to flood CA glue over the seams but that put too much glue on the piece and it was difficult to control. We have just recently cast a bunch of RTV Silicon dowels to fit the 27/64" dia. and the 3/8" dia. barrels which CA won't stick to so that eliminates the need to constantly be removing the brass tube before gluing and also eliminates the accidental gluing on the brass tube into the inlay barrel. We've also found that if you store your disposable brush in the CA glue bottle during assembly, it won't harden and you'll only need one brush to complete the

assembly of your inlay kit. I've knocked several CA glue bottles over doing this, so I made a mode of the bottom of the glue bottle and cast this base to prevent this from happening again.

GLUING IN THE BRASS TUBE



The thin CA glue that you use to assemble the inlay kits works great because it wicks down between the pieces and secures them together well. This glue is only being used to secure the pieces to each other and not to the brass tube. Consider when you turn your finished barrel down to the bushing size on any of the Sierra kits, the thickness of the wood at either end is .0315" or 1/32". Unless you turn a really fat pen, the thickness in the center of the barrel will be .0665 or 1/16". (Dimensions taken from our red rose sample). That is now your gluing surface. That's why it's important to make sure the glue you use to secure the brass tube to the glued up inlay barrel covers every bit of the surface of the inside of the barrel. We recommend 2 part epoxy for its gap filling properties and a higher resistance to vibration and shock than other glues. This means that there's a bit of flex in the glue which is helpful in making sure everything stays put while turning on the lathe. 99% of all issues I've seen with inlay pieces flying off the barrel during turning are a result of either not enough glue on the brass tube/inlay barrel or the wrong type of glue being used. No special turning tools or techniques are needed for good results on the lathe if the brass tube has been properly glued in. Sanding instead of turning is preferred by some people. You run the risk of contaminating lighter woods with dust from darker or dyed woods when doing this.



RED, BLUE AND BLACK DYED WOODS BLEEDING INTO HOLLY AND MAPLE

This issue happens from time to time during the glue-up of the inlay pieces. I have been experimenting with several brands of CA glue as this does not happen with all brands of CA glue. At the time of writing this, Hot Stuff, BSI and E-Z Bond thin CA glues do not cause this. If you're unsure, a good work-around is to brush a thin bead of thin CA glue on any edges of holly or maple pieces that are going to come in contact with any of the darker dyed basswood pieces.

BEST FINISH FOR AN INLAY PEN KIT

Easiest answer to this is all of them. We do a final light pass with a skew using it as a scraper to remove any tool marks and then go directly to a medium CA finish with no sanding until all coats have been applied. We then sand with 220 grit to even everything out and remove any shiny spots. From there we wet sand with micromesh (all grits) and that's it.

PRICING A FINISHED INLAY PEN

Usually if one of our inlay kits is more expensive than another, it's because there are more pieces and it's more involved to assemble. That being said, four times the cost of the inlay kit (without quantity discounts) plus the retail cost of the pen kit (without quantity discounts) equals the selling price. This is a good starting point.

MAKING YOUR OWN LASER CUT INLAY BARRELS NECESSARY EQUIPMENT REQUIREMENTS

You're going to need a laser engraver capable of cutting a minimum of 3/32" thick hardwood. That would require at least a 35Watt laser. Woods like Olivewood, Basswood, Holly Alder, Cedar, and other soft woods cut well on a 35W machine. Exotic woods like Cocobolo, any of

the Rosewoods, Zebrawood, Bocote etc. would usually require a bit more power. The least amount of time the laser beam is in one place the better so the more power you have, the faster you can travel while still being able to cut cleanly through your piece. This makes for a smaller kerf and a cleaner cut resulting in a better overall fit.

You're also going to need a rotary attachment. These are available as an accessory on most laser engravers but not all. With the machine turned off, the rotary is plugged into the laser. When the laser is turned back on the new home position for the rotary is automatically found. The "y" axis of your drawing is replaced by the rotary so now in your graphics program (we use CorelDraw) when you draw a line from the top of your page to the bottom of your page, when sent to the laser that line will wrap around the cylinder.

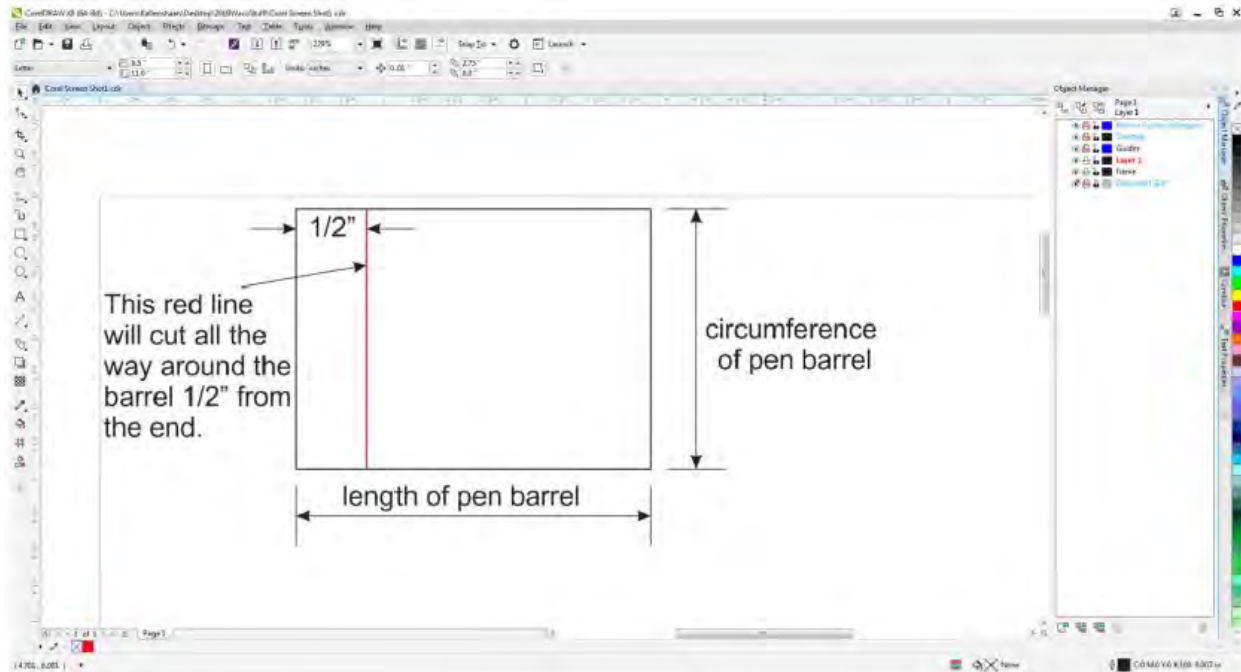

This particular rotary attachment is called a 4 wheel rim drive rotary. You'll notice it has 4 wheels with rubber O-rings on each. These are designed for engraving things like wine bottles glasses, mugs and flashlights. To make this work for something as small as a pen barrel we had to design a mandrel to hold the pen blank and to be heavy enough to allow the mandrel to rotate on the 4 wheels accurately without slipping. We've done a few things to accomplish this. First, we've threaded 1" in on both ends of an 8" long 1/4" steel rod to accept two 1"x1" steel cylinders drilled in the center and threaded to accept the 1/4" rod. We've permanently secured one of the 1" dia. cylinders to one end of the mandrel. The other threads on and off to allow the mounting of the pen blanks. We've also had several bushings made with varying diameters for the different sizes of pen blanks we use. The bushings enable us to mount a blank from either end so we can cut up to 2 barrels at a time on a mandrel. We also have a few 14" mandrels



which enable us to cut 4 pen blanks at a time. To make sure there is no slipping of the mandrels, we have glued a 1" diameter 80 grit sanding sleeve around the end cylinders. These are replaced every month or so. These sleeves chew up the rubber O-rings on the rotary wheels so we frequently replace these as well.

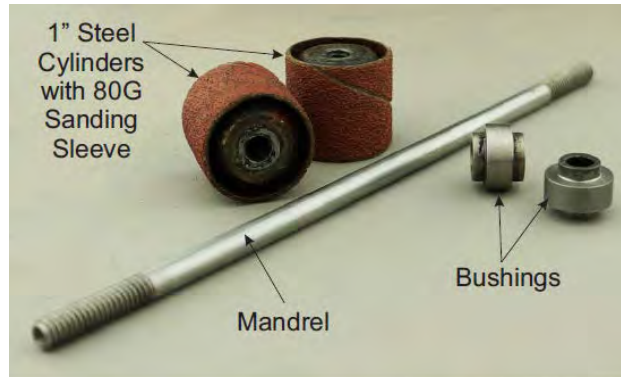

For the artwork you create in your graphics program to translate accurately on you pen barrel, the diameter of the cylinder on your mandrel has to be the same diameter as you pen barrel. This isn't possible for 2 reasons.

1. We need the additional weight of the 1" steel cylinders for the mandrel to rotate smoothly.
2. We're constantly changing the diameter of the pen barrel depending on for which pen kit we're making the inlay.

The size of the drawing in the "y" axis is changed to compensate for the different diameters. Here's the calculation to use.

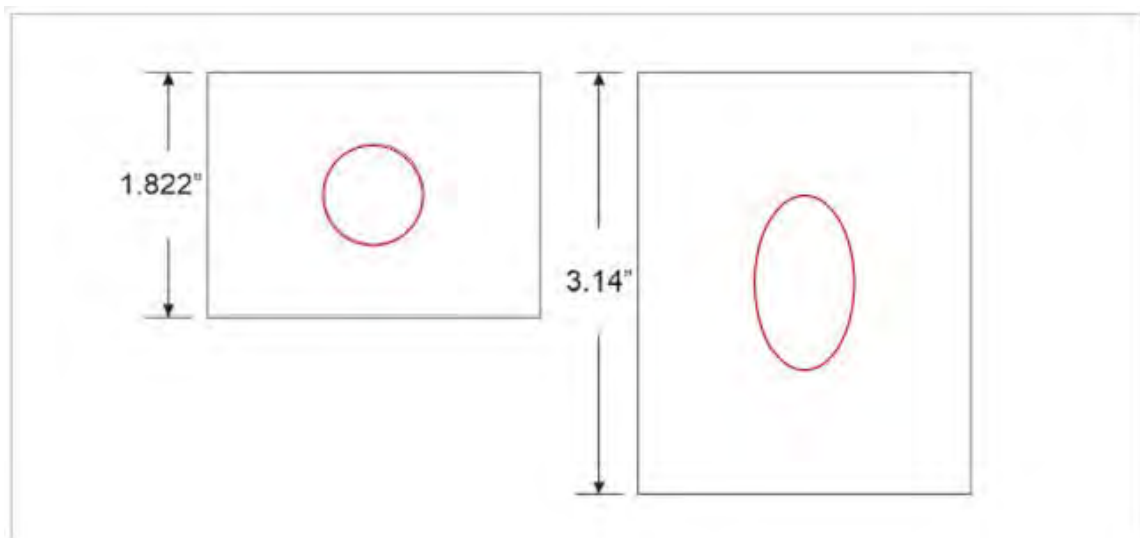
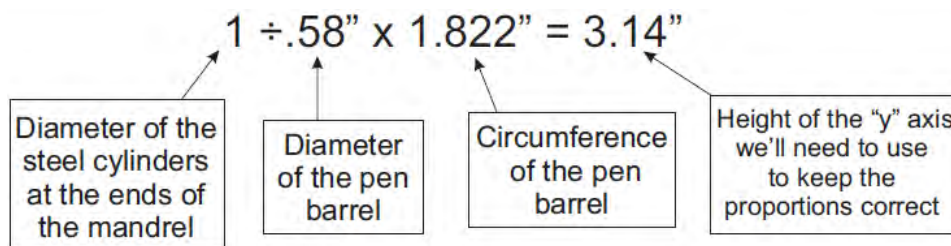

ONE WAY TO CUT A SEGMENTED BLANK WITH A LASER

1 We'll start by cutting 1.77" wide strips from 3 wood cylinders drilled out to 27/64". We're using walnut, pearwood and padauk.

2 Next we'll assemble the cylinders around a 27/64" brass tube alternating the 3 woods and securing with elastic bands as you go.

3 Now slide this assembly off the brass tube and on to our silicon dowel. Brush thin CA glue over all of the seams and spray a bit of Activator over it. Twist the silicon dowel and remove the barrel. Off to the laser to cut the rings.

4 We're going to laser cut 14 of these rings to a width of .14" ea

5 Twist the rings onto the silicon dowel and glue 1 ring at a time aligning as you go.

6 Once the rings are all glued up, the barrel goes back on the mandrel and into the laser to cut the pieces for the segmented vase.

7 Here are a few of the pieces that we're cut from the segmented barrel.

8 The Assembled blank



TURNING 28

WITH LARRY RANDOLPH

[<Link to List of Demonstrations>](#)

Sandblasting



Many artists use sandblasting or sand carving in their work. Pascal Oudet, Bill Luce, Jim Piper, Trent Bosch, Al Hockenbery and others have been exploring this technique for many years with incredible results. Some use it to completely blast away the softer spring growth in a ring to make “skeleton bowls” or pieces that in some instances look more like doilies. Yet others use it to highlight those growth rings while masking off areas to preserve the highly sanded and finished surface. Many of them use the process in conjunction with adding other methods of carving, coloring and amendments to their works.



Woods that have more open spring growth rings make for better sandblasting. Examples but certainly not limited to: Ash, Hackberry, Honey Locust, White Oak, Red Oak etc. make good selections as the softer spring growth is easier to remove through blasting than the harder winter rings. The softer woods like Douglas Fir are what some artists, like Bill Luce, use to make “Skeleton Bowls”.

In this demonstration, we'll discuss the minimum equipment needed into the more elaborate setups if you plan to use this as a regular accompaniment to your turning.

Firstly, as with any shop activity where there is dust, it is most important to protect your lungs. You simply must wear a mask that will protect you from the very fine particulate that sandblasting can create. I use a mask produced and sold by RZ Mast at www.rzmask.com. In addition to wearing a good mask that can filter out the small particulate you should also use dust collection with, at a minimum, enough cfm (cubic feet per minute) to keep the cabinet clear during its use. A shop vacuum “might” work, but a dedicated dust collector would be best.

*****ALWAYS PROTECT YOUR LUNGS*****

There are two main types or systems of sandblasting that would easily be used on wood. The first and most common is the syphon blast cabinet much like the ones sold for under \$200 at Harbor Freight (don't forget the coupon). These systems have a compressed air line that

pushes air over another line that is buried in the abrasive in the bottom of the cabinet creating a suction that pulls the abrasive into the air stream.

For those that may spend hours blasting away on their pieces a second option could be a better though more expensive solution. This style of cabinet has a captured pressure pot system. With these systems, they propel the abrasive from the same hose the compressed air line uses.

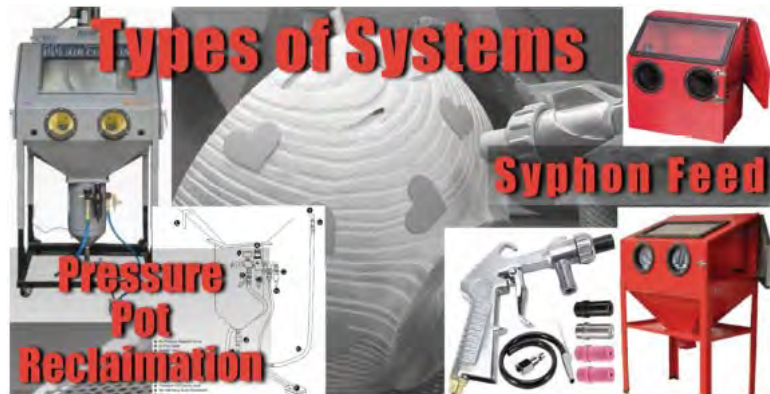

In this demonstration, we'll discuss not only the systems mentioned above, but also the various abrasives that are commonly available and those that are most appropriate for use on wood. There are many to choose from and can be a bit overwhelming. We'll discuss other parts and pieces that can be used to increase your opportunities with this texturing option.

I use sandblasting in various ways and I'll demonstrate blasting an entire piece with no plan other than to give it an aged appearance after blasting. And then I'll also demonstrated a piece that incorporates masking off areas to protect the original surface of the wood. This will include coloring that space under the mask and also the textured surface after sandblasting the soft growth rings away.

In this second example, I start with a 4"x12" ash bowl blank and turn a bowl leaving the tenon. Sanding the bowl up to 400 grit. Then I air brushed red aniline dye completely covering the outside of the bowl.



Sandblast resist or mask allows you to cover an area and protect it from the sandblast media. We'll discuss various vendors and mask products. Using the sandblast resist or mask can be done as simply as using an exacto knife and cutting out various shapes. I use a vinyl cutter (aka plotter) for this along with a software package – "Sure Cuts Alot".

The vinyl cutter came from USCutter at uscutter.com. It is important to note that when using a vinyl cutter for masking, that you use a 60 degree blade and set the downward pressure twice as heavy as you would for standard vinyl.

Once the vinyl cutter has done its work, I can place the masking material on the wood. I must be careful to not touch or interfere with the adhesive on the sandblast resist as it could easily not properly adhere to the wood. Once on the wood, be sure to press it firmly in place to ensure its adhesion.

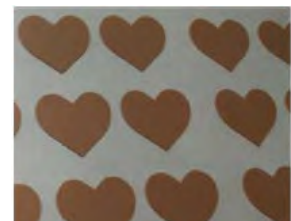



Now that I have the resist material in place, I can use the sandblaster to remove as much of the softer growth rings as I want. This all boils down to preference and the amount of time you are willing to commit to this process. For this piece, I am using coarse ground glass from Ballotini which can be purchased through Amazon.com. The settings are approximately 90 psi which produces 16 cfm from my 80 gallon compressor. Though this can be accomplished with a smaller compressor, you will be limited to shorter blasting times as the smaller compressor will take longer to regenerate the pressure needed. Patience is the key.

Once the softer growth ring is carved away by the abrasive media, I then use my air compressor nozzle to blow any remaining dust or media off the piece.

Then I paint or dye that area with the color of my choosing. In this instance, I used my airbrush and a black aniline dye (Artisan from www.thewalnutlog.com). Other dyes can be used, but I find that Artisan sets a little quicker. It is important to make sure that you paint from two or three different directions to ensure you cover all sides of the adhesive mask for crisp lines.

Paints I use: Golden HiFlow, Krylon Short Cuts flat black or you can also use Marsh Ink. All available from Amazon.com.

My dye of choice: Artisan from www.thewalnutlog.com

After coloring the uncovered blasted area with the base color then I use a dry brush technique to apply a top coat color. This particular color is Mylands metallic silver paint also available from www.thewalnutlog.com.



Once the softer growth



Dry brushing is achieved by barely grabbing paint on the tip of a stiff brush, a good stiff chip brush will work. Make sure that you have paper or a paper towel to remove the excess from the tip of the brush. Basically, you are just barely leaving residue on the piece by briskly slapping the brush back and forth over the wood. You shouldn't see much come off the brush. Remember that it is easier to put more on, but you can't take it back off. So, be patient.

Then after the dry brushing is completed and dry, I gently remove the masking material, being careful to get all of the tacky adhesive off of the piece.

Once all of the mask is removed, I give the outside and rim 3 or 4 light coats of a matte lacquer. After the lacquer has cured, I turn out the inside and finish it with Mylands Sanding Sealer, Yorkshire Grit and Hampshire Sheen. I can then reverse it, remove the tenon and use the same finishing regiment as I did on the inside: Mylands Sanding Sealer, Yorkshire Grit and Hampshire Sheen.



As stated, this demonstration will have many aspects to it, general sandblasting information and the tools and equipment needed to get started. Then once the equipment is accumulated, how to use it in several different ways to create more textural interest in your woodturning.

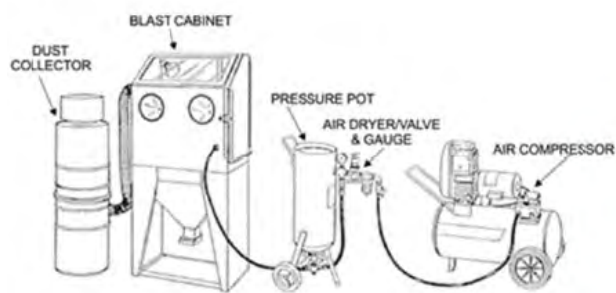

Resources

M2 Mesh Reusable Dust/Pollution RZ Mask – www.rzmask.com

Basic syphon feed sandblast cabinet: Central Pneumatic – Harbor Freight 40 lb Model

Minimum 30 gallon air compressor capable of 9 cfm @ 90 psi

Sandblast Mask – Anchor T227, 22 mil BlastLite – www.uscutter.com

Ballotini Ground Glass Blast Media (coarse) – Amazon.com

Artisan Dyes – www.thewalnutlog.com

Golden HiFlow, Marsh Ink – Amazon.com

Mylands Metallic Paint – www.thewalnutlog.com

Mylands Sanding Sealer – www.thewalnutlog.com

Yorkshire Grit – www.thewalnutlog.com

Hampshire Sheen – www.thewalnutlog.com

I'm happy to answer questions after the demo.





TURNING 28

WITH BRIAN SCHRADER

[<Link to List of Demonstrations>](#)

Three and Six Pointed Winged Vessels



The shapes that might emerge from a cube are limited only by your imagination. These might be simple 3-pointed bowls, lidded boxes or more challenging 6-pointed hollow forms with finial lids.

Determine how large a cube you want:

How large a cube do I want? That depends on the desired end piece and the throw of your lathe. A small Christmas ornament can be turned between centers and can start with a small block. A bowl or hollow form will need to be mounted in a jaw chuck and will need a larger block. When the cube is placed on the lathe, the cube will rotate on an axis between opposite diagonal corners and the remaining 6 corners are going to swing a larger radius than the sides of the cube. This is an interesting characteristic of this style of turning that will be more evident in the demonstration, or when you try this in your own shop. I use a general 9/16 rule to evaluate the maximum cube that might be turned on a lathe. If you have a 16" throw on your lathe (8" radius between the axis and the ways of the lathe bed), then the general rule allows a cube to be nominally 9". Keep in mind you also need space to position and move the banjo. The desired "points" that emerge from the cube are delicate and it can be disappointing to fracture a point when positioning the banjo.

Cut the cube to be square and even:

We need a block of wood that is a near perfect cube. The block can be trimmed with virtually any type of saw; band saw, table saw or a miter saw. The steps outlined here are based on the use of a band saw, but can be modified to accommodate the size block and equipment to be used. To trim your stock to a cube, first check the setup of your saw. If the blade is not perpendicular to the table, the faces of the cube will not be correct and your finished piece will be irregular. I rough cut a blank nominally 1/2" oversized size for the desired finished cube. I

have found that I get best results when I think of the rough wood block as a common 6 faced die. With a smooth, straight stroke through the saw, cut face “1” of the cube, removing approximately $\frac{1}{4}$ ” of the oversize allowance. Using that cut face against the table, cut face “2” perpendicular to face “1”. Now keep face “1” against the table, and place face “2” against the miter guide, push the block through the saw to cut face “3”. If the saw blade, table and miter are set correctly, this will create faces “1”, “2” & “3” in the desired perpendicular relationship. Now set the rip fence to the desired finished cube dimension. Rotate and roll the rough shape so that one of the three reference faces “1”, “2” and “3”, is always against the table and one reference face is always against the rip fence. With 3 cuts, you will generate each of the remaining faces “4”, “5” & “6”. If the rip fence and miter guide are set correctly the opposite faces of the cubes will be parallel, adjacent faces will be perpendicular and the length all 8 edges will be identical.

Setup on the lathe:

Once the block is shaped to a cube, we are ready to go to the lathe. How do we chuck this odd shape? What chuck works best? For the initial attempts at this style of turning, I recommend turning between centers with no chucks at all. I remove the jaw chuck from the headstock and insert one corner of the cube into the hollow spindle as illustrated in Figure 1.



Figure 1: Corner inserted in Hollow Spindle



Figure 2: Cube secured in Hollow One-Way live center

Bring the tail stock up to support the opposite corner in the hollow center of the One-Way live center as illustrated in Figure 2. (You may need to remove the pin from the live center.) Position the tool rest to check the sweep of the points during rotation. On the tool rest, mark the position of one point and determine if the other points repeat the position of the passing points. This is shown in Figure 3. If the points do not pass the marked position on the tool rest, try slightly shifting the corners inserted in the hollow bores of the head & tail stocks and repeat the alignment check. If after repeated attempts, the points do not align, check the square-ness of the cube. Once the points repeat the location passing the tool rest as close as possible, tighten the tail stock and recheck the points passing the tool rest.



Figure 3: Mark the location where the cube corner swings past the tool rest

With the tail stock tight against the cube, there will be sufficient friction against the head stock to spin the block. This friction drive offers a nice anti-catch feature as any catch simply stops the rotation of the block. The initial turning is an intermittent cut and even small catches will tend to stop the rotation. If the gauge can't be brought up to the block without stopping the rotation, tighten the tail stock to create more friction. Like all turning you will start the piece in a slow RPM and increase the speed. Unless the block was extremely non-uniform the center of mass of the cube will be on center and the block will rotate smoothly with virtually no vibration at moderately high speeds. Once you have some experience with the friction chuck, and you want to do more pointed shapes, a special chuck can be homemade or purchased. (Search '3 Point Chucky' from Rubber Chucky Products, LLC.)

Shaping the vessel:

Now we are ready to start generating chips! Stand back and examine the ghost or phantom shapes as the cube rotates. Be aware of the rotating corners of the cube and always keep your tool rest out of the path, but more importantly always keep your hands on the operator side of the tool rest and avoid the temptation to place delicate flesh in the path of the cube. As the shape develops moving the banjo and tool rest will be a challenge to reduce the overhang and chatter on your cutting tools.

At some point you will need to cut a tenon and clamp the block in a jawed chuck. It might be surprising how far into the corner of the cube you must cut to develop a tenon to fit your jaws. You can start shaping the block in the friction drive set up, but don't go too far without developing the tenon. It is disappointing to rough out your shape and prepare to cut the interior of the bowl or start hollowing, only to find the tenon you need encroaches on your form.

Once you have the tenon cut and the block mounted in the clamping jaws you are ready to start the shaping of the block. Mechanics of cutting the block and cutting the tenon have controlled the approach to this stage. Now imagination and creativity take control of the direction moving forward. The two primitive sketches below illustrate a simple 3-point bowl and a 6-point hollow form.

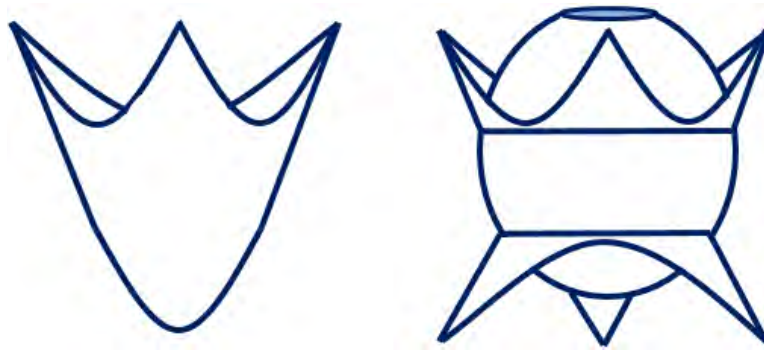

Illustration 1: Simple 3-pointed Bowl and a 6-pointed Hollow Form

There are many YouTube videos on ‘Bowl from Cube’ or ‘3-winged/Pointed Bowl’, etc. Most of the videos follow the very basic, 3-pointed bowl form illustrated in the sketch above using the natural shape of the cube and only round off the corners. Don’t stop there! Experiment!! Alter the profile of the sides. Try an Ogee shape allowing the points to roll out as petals of a flower blossom. With very little modification to the approach, the 3-pointed bowl can be turned into a lidded box with points.

For the more adventurous, try the 6-pointed vessel. The body of the vessel can be a bowl or a hollow form. With this style vessel three points sweep a plane and the remaining three points sweep a parallel plane. Depending on the angles you cut the gap between the two planes is some form of “V” or “U” shape. You potentially will have a long overhang on your gouge when trying to cut this area between the two planes. To reduce the vibration, you may need to use a larger gouge. You may need to reposition the banjo and the tool rest to get deeper into the “V”. Be aware at all times where the points are spinning and the limited work area available in the “V”. I have fractured points on the opposite side of the “V” from where I was cutting by encroaching on the free spinning points.

Regardless of whether making a 3- or 6-point vessel, at some stage you will need to remove the live center and hollow the bowl area or drill for a hollow form. While running the lathe always be aware of the spinning points and where you are placing tools and fingers. Always stop the lathe before repositioning the banjo. If you are turning a block that is near the throw of the lathe be aware of where the ‘down’ points might be. The points are delicate and it is extremely frustrating to fracture a point by impacting it when moving the banjo. (Voice of experience.)

Sanding and finishing:

Once the shape is complete you enter the realm of sanding. Again, be careful! Sanding many areas of these vessels is safest when performed with the lathe at the absolute slowest speed... STOPPED! When finished sanding, remove the vessel from the jaws, reverse chuck it with a jam chuck or vacuum chuck and turn away the tenon. Now apply a finish of your choice.

Don’t forget to sign and date the piece so your friends know you made this vessel and make them wonder how.



TURNING 28

WITH DREW SHELTON

[<Link to List of Demonstrations>](#)

Turning a Burl Cap



To begin, decide what the “center” of the burl will be. This is usually the thickest part to allow for the deepest bowl possible or at the center of mass to reduce vibration. These points will almost certainly not be the same. Note the shallow areas that could end up as holes in the bowl. However you choose to center it, cut a round piece of plywood large enough to center the burl on so that there are no overhanging edges. Mark the center on both sides.

Cut 3 or 4 large wedges from scrap 2x4. Lay the plywood flat. Stand the burl on it with the natural side down and the cut face as level as possible. Use the wedges to support the burl and keep it in that position.



Measure the maximum height from the plywood to the burl. Cut *lots* of thin strips of scrap wood of varying lengths, no longer than the maximum height. I usually cut several pieces from the end off of a 3/4" pine board at a slight angle and slice it thinly with a bandsaw. Cut the strips with the grain. Save the small wedges at the thin ends to start the gluing process.

Find a place where a small wedge will fit under the burl and provides as much contact as possible with the burl's surface. Use hot melt glue to attach it to the plywood board and the burl.

Continue to build the wedge using the thin strips. The wedge should conform to the surface of the burl as much as possible. I use a sanding disc to tweak the length and shape of each strip as necessary. Glue each strip to the piece that came before it, as well as the plywood and the burl.



Continue to build the wedge. Don't go all the way to the edge of the burl, otherwise truing up the face could start cutting the wedges.



Keep building wedges. Once the second one is started, you should be able to remove the temporary 2x4 wedges. I build at least 5 wedges.



Turn it upside down and attach a faceplate.





Mount it on the lathe. Use the opportunity of this new perspective to fill in the gaps in the glue between the wedges and the burl. Put a bead of glue around the base of each wedge.

Lock the spindle. Grab the burl and try to move it. If it moves, you'll need more wedges.

Bring up the tailstock, turn down the speed, and start the lathe. Increase the speed slowly to the vibration level you and your lathe can tolerate. True up the face. Once it's true, begin shaping, remembering where the thin spots are. Keep the tailstock up as long as possible.

When completed, use a spray bottle of isopropyl alcohol to loosen the glue. Grab the wedges with a pair of pliers and twist them off. Examine the surface for stray bits of glue. Apply more alcohol and use tweezers.

Here are 3 views of the final piece.





TURNING 28

WITH JIM SWANK

[<Link to List of Demonstrations>](#)

Making Pen Blanks from Bottle Caps

In part 1 of this demonstration, I will demonstrate how I make pen blanks from bottle caps.

List of Supplies:

- Tin snips or metal shears
 - Channel lock pliers
 - Chain saw file
 - Arbor Press
 - Dapping block – homemade or commercial
 - Transfer punches
 - Tubes
 - Nail Polish
 - Sturdy knife
 - Band-Aids/first aid kit
 - Needle nose pliers
1. Use metal shears to cut up between the crimp marks on the cap. This leaves a “hula skirt” appearance. Next bend the tabs out like the rays of the sun. Then pry or scrape off the plastic or cork liner. Trim around the edges of the bottle cap top. Flatten with the press and block of wood, then bend to rough fit the tube.
 2. Apply self-adherent tape to forefinger, thumb, and middle finger of left hand (right hand if left-handed). Hold bent cap in left hand and use tube as a gouge to scrape any liner residue out. Use chainsaw file to smooth serrations from shear on the inside of the blank so you don't scrape the tube during assembly.

Form tube to transfer punch smaller than tube. Bend wings in a little bit with needle nose pliers. Finish rounding out cap in a dapping block on press. Trial fit to raw tube. Slide on painted tube and inspect.

In part 2 of this demonstration, I will demonstrate how I make pen blanks from stamps.

List of Supplies:

- Sharp Scissors
 - Tubes
 - Nail Polish
 - Sharp knife
 - Band-Aids/first aid kit
 - Clean scrap paper
 - Elmer Craft Bond extra strength glue stick
 - Thin or thinner medium CA
 - Viva paper towels
 - Wooden toothpicks
 - Rubber bands
 - Lathe, pen mandrel and face shield provided by SWAT
1. First, I will discuss stamp adhesives – pressure sensitive (peel & stick) and mucilage (lick & stick), my observations on what they will adhere to, and differences in tube preparation for each.
 2. Second, I will discuss sizes of stamps and ways to lay them out on a tube – straight or spiral, right or left handed spirals, use of a paper template to lay out your stamps.
 3. I will apply some mucilage type stamps with the glue stick, and trim the ends with a sharp knife after the glue has dried.
 4. I will lay out some PSA stamps on a tube, trim the overhang with a sharp knife, and demonstrate sealing the stamps with CA prior to casting, using a toothpick to further seal the seams on PSA stamp blanks at the very ends of the tubes.

If time permits, I may briefly discuss mechanics and stresses on layers and boundaries with some rough sketches on a white board or easel.



TURNING 28

WITH MALCOLM TIBBETTS

[<Link to List of Demonstrations>](#)

Getting Started with Segmenting Compound Miters and Ribbons Tubal Segmented Constructions



MATHEMATICAL FORMULAS AND CONCEPTS:

A circle contains 360°

Circumference = Diameter x π (3.1416)

Diameter = Circumference / π (3.1416)

Segment length = Circumference / Number of segments

Segment Angle = 360 / (2 x the Number of segments)

Number of required segments = Circumference / Segment length

(Number of segments x Segment length) / π (3.1416) = Diameter

CALCULATING COMPOUND MITERS:

(using a calculator with trig functions)

Miter Angle (MA) = inverse tan $\left\{ 1 \div \{ \cos S \cdot \tan[360 \div (2N)] \} \right\}$

Blade Angle (BA) = inverse tan (cosMA • tanS)

MA is the miter angle

S is the slope of the vessel (measured from horizontal to side)

BA is the saw blade angle (the bevel cut)

N is the number of staves

CONSTRUCTION OF PLATONIC SOLIDS:

Shape

Miter Angle

Tetrahedron (a form built from four triangles)

54.735°

Hexahedron (a six-sided cube)

45.000°

Octahedron (a form built from eight triangles)

35.264°

Icosahedron (a spherical form built from twenty triangles)

20.905°

Dodecahedron (a spherical form built from twelve pentagons)

31.717°

VESSEL BUILDING BASICS:

- Draw shape first, using either graph paper or computer.
- Overlay rectangles to represent ring layers.
- Overlay smaller rectangles to represent segment widths.
- Calculate segment lengths $((D \times 3.1416) \div \# \text{ of segments})$.
- If the vessel has many layers, create a “cutting list”.
- Mill your wood to consistent dimensions prior to cutting the segments.
- Cut widest segments first to conserve wood.
- Sand segment ends (or don't, it's up to you).
- Glue rings together using either “rub joint” or “half ring” method.
- Build base ring (if the base diameter is larger than 2 ½”, consider using a “floating” base).
- Stack laminate rings “one at a time” to insure centering.
- Use a flat sanding block prior to gluing next ring in the construction.
- Consider building the vessel from both directions at the same time and then joining the two halves.
- Rough turn as you stack, but maintain plenty of wall thickness until you have determined the final shape.
- Use masking tape barrier to avoid glue squeeze-out contamination on inside during the joining of two halves.
- Sand to at least 400-grit, reverse-mount, finish and sign bottom.
- Seal with plenty of protection to minimize wood movement.

Remember...

- Use only dry wood (under 10% moisture content).
- Avoid intersections longer than 1” of opposing wood grain orientation (shorter if possible).
- Always consider the shape as the most important design element (more important than wood type, color combinations, etc).
- Never glue two surfaces together that do not fit perfectly and remember, a sanded joint will usually be stronger and have a better appearance.
- Do not resort to “filling” a joint imperfection; re-do or replace as necessary. The defect will usually show and you will inevitably regret the lack of perfection later.
- Avoid an abundance of “oily wood to oily wood” glue joints.
- Keep, and inform others to keep your turnings from excessive exposure to direct sunlight.

A SAMPLE DRAWING:

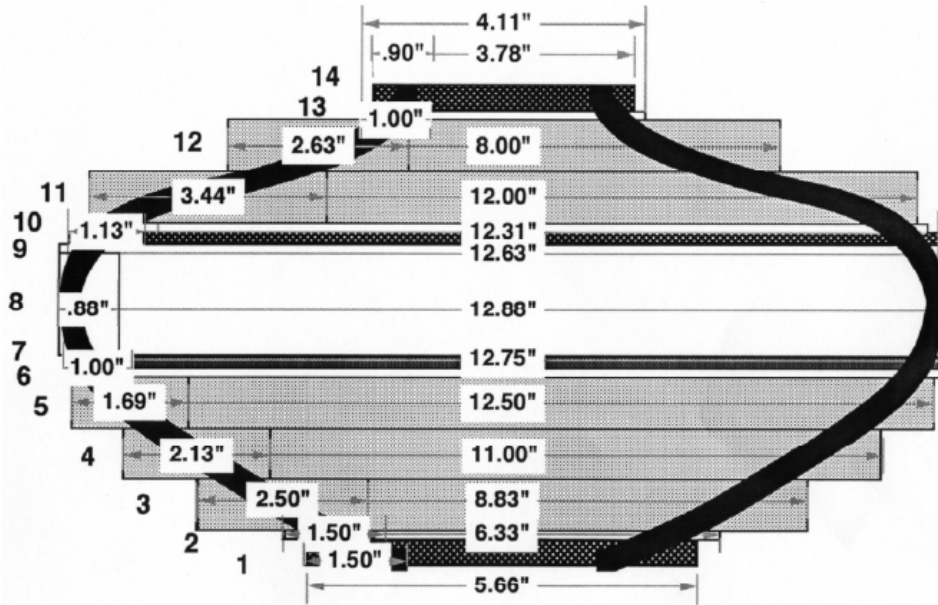

A SAMPLE CUTTING LIST:

Ring Number	Ring Diameter*	Miter Angle	Number of Segments	Width of Segments*	Height of Segments*	Length of Segments*	Wood Type	Board Length**
1	5.66	18 °	10	1.50	0.40	1.78	ebony	18
2	6.33	18 °	10	1.50	0.13	1.99	holly	20
3	8.83	9 °	20	2.50	0.80	1.39	bubinga	28
4	11.00	9 °	20	2.13	0.80	1.73	bubinga	35
5	12.50	9 °	20	1.69	0.80	1.96	bubinga	39
6	12.75	9 °	20	1.00	0.13	2.00	holly	40
7	12.75	9 °	20	1.00	0.19	2.00	ebony	40
FEATURE	12.88	18 °	10	0.88	1.63	n/a	n/a	n/a
9	12.63	9 °	20	1.29	0.19	1.98	ebony	40
10	12.31	9 °	20	1.29	0.13	1.93	holly	39
11	12.00	9 °	20	3.44	0.80	1.89	bubinga	38
12	8.00	9 °	20	2.63	0.80	1.26	bubinga	25
13	4.11	18 °	10	1.00	0.13	1.29	holly	13
14	3.78	18 °	10	0.90	0.40	1.19	ebony	12
* all figures represent inches								
**rough estimate based on the length of segments times the number of segments								

PEN BLANK BOWL PHOTOS

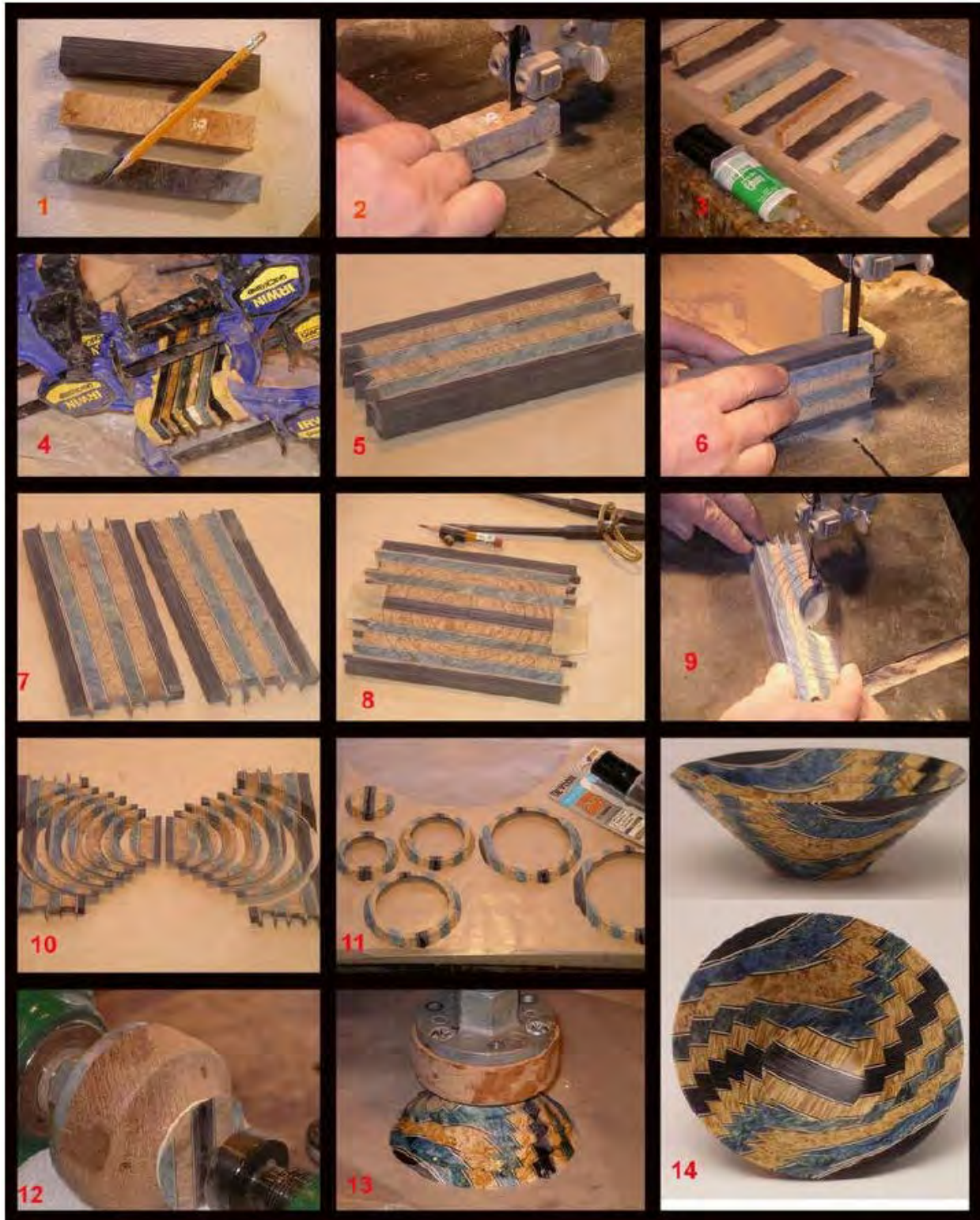

CHECKERED HOLLOW FORMS

This technique can be adapted to many sizes and shapes, but the basic procedures remain the same,

1. Select two woods with good contrast (a light color and a dark color). More than two colors will also work if you align the pieces appropriately.
2. Mill an equal number of identically dimensioned strips of each wood. Once again, variations in width will work if they are assembled in the correct order. For your first attempt at this technique, I suggest keeping things simple with just two different woods, milled all the **same thickness** (very important).
3. Glue together strips into a “cutting board” style lamination. In general, the lamination should be about 3 or 4 times longer than its width.
4. Clean up the lamination.
5. This step is optional. Re-saw the lamination(s) lengthwise and clean them up into identical thinner laminations. If you skip this step, your vessel will just have taller individual layers.
6. Using the final width and thickness of your lamination(s), design a vessel shape. The height of your vessel should be a multiple of your lamination thickness. For example, if your lamination(s) is ½” thick, your vessel might be 10 layers tall or 5” tall. The width of your lamination will determine the maximum diameter of your design.
7. Use a compass and draw circles on your lamination(s) being very careful to place the point of the compass precisely into the middle seam of your lamination.
8. Using a bandsaw, cut discs from your lamination(s).
9. Use a compass to transfer diameters from your paper design to the discs.
10. Place double-sided tape on the opposite side of the disc and then using your lathe tailstock’s cone center, position the discs onto a backing plate on your lathe. Be extra careful to position the disc as centered as possible onto the backing plate.
11. Use a thin parting tool to cut individual rings from the disc(s). Place the cut disc onto your design blueprint and confirm that you have the correct outside and inside diameters for each ring. It’s a good idea to label the discs before things become confusing.
12. Using your tailstock’s cone center, glue the base disc onto a waste block. Do the same thing with the top disc onto another waste block.
13. True up these discs and proceed to add more rings. You may want to join two rings together in order to speed up the assembly process. Use a magnifier to inspect the seam intersections. You should only have to focus on the two end grain sides; the other intersections should line up automatically.
14. As you stack laminate the rings into the vessel shape, do a minimum amount of turning. Keep the vessel wall as thick as possible until most of the assembly is completed.
15. Join all rings to form two halves of the vessel. The final seam location is your choice. I usually locate my final seam just above the center line.
16. Individually turn the outside of each half. Frequently hold the two halves together in order to determine and create the most pleasing profile.

17. Turn the insides creating a consistent wall thickness.
18. Remove the top half from its waste block. A parting tool works.
19. Using your tailstock cone as a centering device, glue the two halves together.
20. Finish turn the outside profile.
21. Apply sanding sealer (or proceed with your favorite finishing process).
22. Scrape sanding sealer off and apply another coat. Repeat as necessary to fill the wood pores.
23. After scraping the last coat of sanding sealer, proceed to sand the vessel.
24. Apply finish coats of your choice.
25. Remove vessel from waste block and finish the underside.
26. Sign your work.
27. Have fun!



TURNING 28

WITH BARRY TODD

[<Link to List of Demonstrations>](#)

Shades of Tiffany

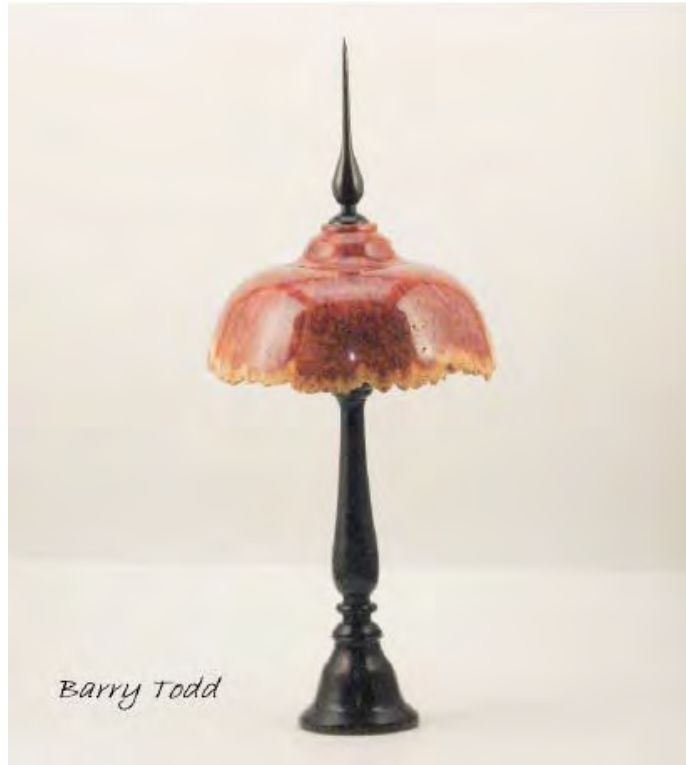

A lamp form lidded box inspired by the art of Louis Comfort Tiffany and Cindy Drozda

Although the first few pieces in this series were produced using burl caps to turn the “shade” portion of the lamp, the possibilities and combinations of wood and techniques that can be used to make this from are limited only by your imagination. More recent pieces show just a small portion of the variation possible with the lamp form. One could use any combination of contrasting woods, pyrography, carving, dying, painting and who knows what else to make a lamp form lidded box.

Step #1 – I start with a round blank approximately 6” in diameter and half that in thickness. This is mounted between centers with the side that will become the bottom of the shade facing the headstock. Attention should be paid to this side to reduce the variation of highs and lows, which would result in an uneven rim along the bottom edge of the shade. This will need to be addressed when using burl, natural edge or irregular shaped blanks.

At this point, the shape of the shade is created using a spindle or bowl gouge (based on personal preference) leaving an approximately $\frac{1}{4}$ " spigot, about $\frac{1}{2}$ the diameter of the shade on what will become the top. I then sand as necessary.



Step #2 – The second step involves removing the piece from the lathe, reversing directions and capturing the spigot in a 4 jaw chuck. Then, using a small bowl gouge hollow out the bottom, leaving a flat bottomed cone that tapers from approx. 2" at the bottom to slightly larger than the diameter of the spigot on top. Create a small groove a $\frac{1}{4}$ " from the bottom of the cone. This will serve as a spigot for the next step.

Step #3 – Once again, remove the piece from the chuck, reverse and re-chuck on the newly created spigot at the bottom of the central cone. At this point we will remove the material where the box will be. Remove the material while tapering the walls to mirror the taper on the underside, to a depth of roughly $\frac{1}{2}$ the thickness of the shade. As I begin to hollow out the box, I leave a small portion of the original spigot as a reference to remind me of the maximum diameter of the box I.D. Once the box is hollowed and sanded, I use a $\frac{1}{8}$ " parting tool to remove the reference ring and create a recess at the outer edge of the box where the lid will seat. Be sure to have the bottom of the recess slightly larger than the top edge, as this is where the piece will be captured for the next step.



Step #4 – Once again, reverse the piece, this time, capturing the piece by expanding the chuck in the newly created recess at the edge of the box. Once secure, mount a keyless chuck in the tail stock with a 3/8" Forstner bit, and drill a 1/2" to 5/8" hole in the bottom of the cone. Pull back the tail stock and then round off the shoulders at the bottom of the cone, leaving a "button" on the bottom of the cone roughly 3/4" in diameter by 1/8" in height, surrounded by a small flat area surrounding the button. This will serve as a secure mounting point to the stem of the lamp form. Any final sanding of the underside can be done at this point.



Turning the lid - Turn a blank from the same wood as the "shade", with a diameter slightly larger than the opening of the box and 2" to 2 1/2" in height. Mount the blank in a chuck and drill a 3/8" dia. hole completely through the blank, then mount the drilled piece onto a worm screw in the chuck. Turn the diameter to the correct dimension of the box opening. Next clean up the bottom of the lid piece. I like to create a slightly concave surface, and then sand. Remove the piece from the worm screw, reverse and remount on the screw. At this point, turn the final shape of the lid, taking into consideration the thickness of the lip and a shape of the lid that blends with the curve of the shade, creating a double ogee.

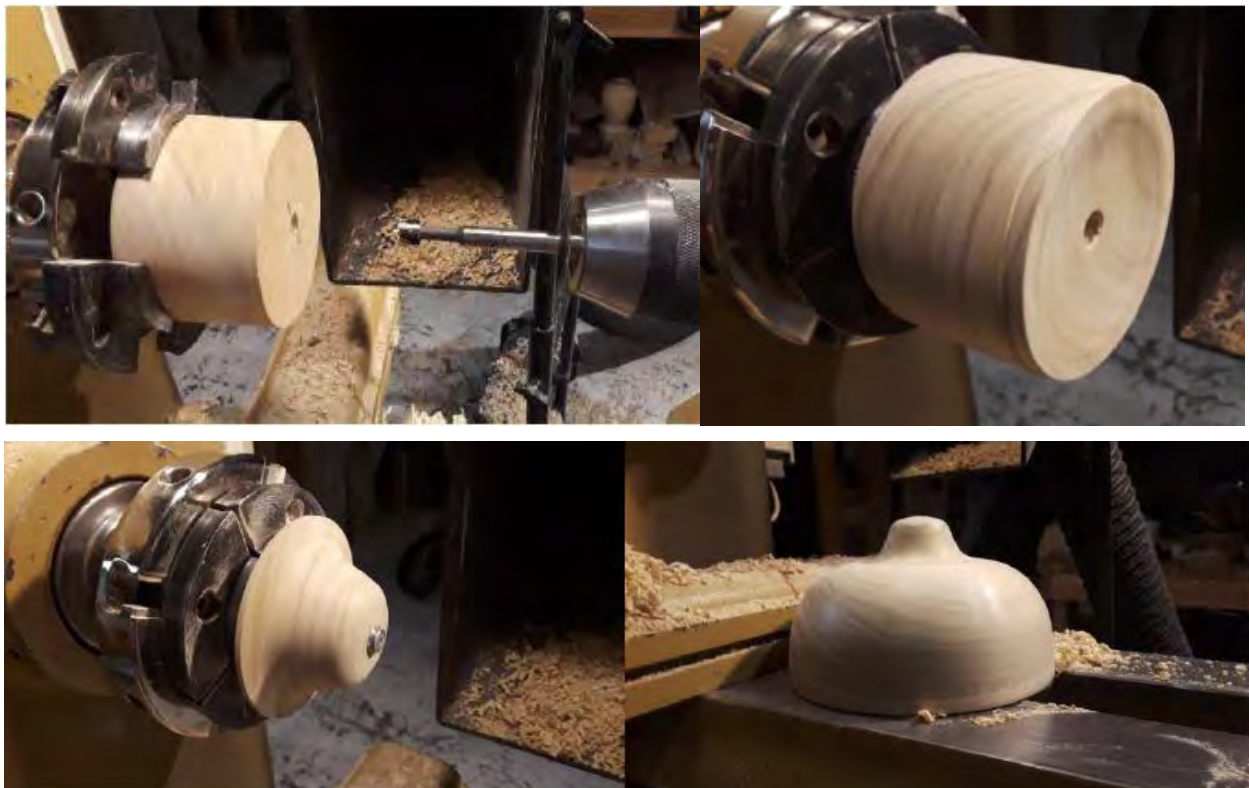

At this point, you've created a lidded box! All that remains, at this point is some basic spindle work to create a top for the lid and a base, as well as a couple small buttons to fill the remaining open holes.





TURNING 28

WITH LARRY ZARRA

[<Link to List of Demonstrations>](#)

Mini Hollow Forms



The objective of this demonstration is to turn a small hollow vessel and a very small hollow vessel while discussing tools, techniques, and design considerations. The small vessel will be turned from a green wood blank with side grain orientation. So, how small is small? The resulting piece will be around the size of an orange or grapefruit. The very small vessel will be turned from a dry blank with end grain orientation. The resulting vessel will be around the size of a walnut.

SMALL HOLLOW FORM

Wood Selection and orientation

- Wood selection is a matter of availability, workability and aesthetics. Any wood that will stay on the lathe for the entire process will work. That said, it is best to avoid punky or highly spalted woods as strength and integrity of the wood can be compromised. Also, avoid blanks with large voids. A high percentage of negative volume can work on a larger scale but, in my opinion, rarely looks good on small vessels.
- Green wood will be easier to shape and hollow than dry wood, but may not be easy to sand. Consider selecting woods that sand easily when wet. This might include oak, pecan, mesquite, mulberry, bois d'arc, and many others. Some woods are difficult to impossible to sand when wet. I turn finished shapes, air dry, and sand later with the vessel jam chucked and between centers. Some hand sanding is inevitable with this technique. The alternative is to turn dry blanks. Dense exotic tropical hardwoods such as cocobolo, ebony, padauk, etc. are not my favorite choice for hollow vessels because they are expensive, dense, brittle, and very dusty to turn.
- The best choice for grain orientation is side grain. End grain pieces are certainly doable, but the larger the vessel, the harder it is to hollow out efficiently. With side grain vessels, the weak point is where the chuck holds the blank. With a compression grasp on the blank, care must be taken to tighten the chuck sufficiently to hold the piece, but not so tight as to shear off the temporary spigot. This is especially relevant with turners or equipment prone to catches.
- Orientation of the grain in the vessel is as not quite as important in small vessels as is it in larger forms. In general, the grain should be symmetrically disposed through the vessel, but other orientations may work just as well. Be aware that sapwood and heartwood have different movement rates during drying, so it's best to not have large parts of the vessel include sapwood. A minor accent of sapwood or bark inclusion should not distort the form too much. A lot of dramatic grain can result from vessels cut from the bifurcation of a limb or trunk. Vessels situated closer to the bifurcation point are more likely to contain interesting flame grain and bark inclusions, and also structural weaknesses. Hollow vessels turned sidegrain from a full round log or branch will include the pith somewhere around the middle of the vessel. This may result in some checking, but this is not necessarily a bad thing. Like other defects in the wood, radial checking around the pith can be manipulated to be a design feature rather than constituting a flaw in the finished vessel.
- 99% of my small to large hollow vessels are turned from green wood, and are hollowed out in a continuous session. If I have to step away for more than a few minutes, I leave some fresh wet shavings inside the vessel, and cover it with a plastic bag. If I will be gone for more than an hour, I will remove the blank from the chuck to minimize staining that can result from the metal chuck jaws reacting with tannins in the wood. Sure beats turning away ugly black spots later on. (I have no experience rough turning hollow forms, drying them, and then finish turning them later. Some turners do this successfully.)

Tools and turning techniques

Small hollow forms are a good size for working with hand held hollowing tools because they involve less torque than larger forms. Also, since they are quicker and easier to turn you can get more practice pieces done in less time. Other reasons to turn small hollow forms are to try

out design options or to make a test piece from a new batch of wood to assess workability characteristics.

Start between centers

- Select wood and cut it to a rough cylinder to facilitate mounting. When cutting blank pay attention to grain orientation and any defects or potential design elements in the wood. This is really the first step in designing your vessel. The placement of a boring, bark inclusion or other defect is interesting if it is in a focal part of the vessel, which is commonly in the upper half or third, including the rim or aperture. It should look like its placement is deliberate. An interesting insect boring situated at or above the maximum diameter of the vessel is a design feature, while the same boring at the base of the vessel is a critical flaw, as it appears to be hidden, or unintentional. On a well-rounded vessel, the maximum diameter is a visual focal point...the inflection where the eye traces the profile or line of the form. Design features at or just above the maximum diameter seem aesthetically appropriate. For many forms, the maximum diameter should be above the measured halfway point from the base to the rim. This give the piece a visual “lift” or sense of lightness. In contrast, a vessel with the maximum diameter below the median height of the piece will almost always seem heavy and clunky.
- Mount between centers and trim to a cylinder to help with balance and allow you to assess grain and possible defects. This is your **Last chance** to flip orientation.
- Establish width and general height of foot or spigot to fit chuck ($\sim 2''x^3/8''$)
- Establish general shape of vessel using fast shear slicing cuts. **This is the first critical design phase.**
- Refine foot; establish 90° angle between foot and transition to vessel using detail gouge, parting tool or skew. Allow small raised margin or shallow step to ease refining vessel base later on. This step also limits potential bleeding of stain onto vessel resulting from tannins reacting with the chuck.
- Refine shape of vessel using bevel rubbing cuts first, and then shear scraping. **This is the second critical design phase.**
- Recheck foot for true alignment and angle. Remove vessel from centers and mount in chuck.

In Chuck

- True up rim and make any final adjustments to upper quadrant of form if necessary. Shear scraping is a good cut to use here because it removes very little material and also applies very little stress to the vessel.
- Begin hollowing with straight cutting tool. Cut cylinder to near final depth. Widen as practical while stopping regularly to clear shavings. Shavings can be removed by scraping them out, scooping them out, blowing them out, sucking them out, or shaking them out.
- Start to thin wall with angled cutting tool. Clear shavings, measure, and repeat. Make smooth cuts while visualizing the tip of the tool following the contour of the vessel. This takes a bit of practice. Some turners cut away the interior of the vessel step by step (Jordan), using the previously cut steps as reference points. This is more useful in larger vessels. Other turners remove the interior in layers (Ellsworth), visualizing or approximating the external shape. This approach may be more suitable to smaller forms. I call my small

hollow vessels “finger pots” because I can use my fingers as calipers to check the wall thickness at most stages. **Measure after every cut when approaching final stages of hollowing.**

- As wall thickness approaches a finished dimension, it is important to get the vessel depth correct. The base of the finished form should be around the same thickness as the vessel walls. A depth gauge is more helpful than calipers. This step is important because it affects the balance of the form when you pick it up. If the base of the vessel is more than twice the wall thickness, the piece will feel anomalously heavy. Alternatively, if the base is much thinner than the vessel walls, it will feel anomalously light and top heavy. Taken too far, and we have a decorative funnel. When done hollowing, sand completely and remove vessel from chuck. Measure maximum depth and record. I make sure to retain final depth measurement on the depth gauge for this. A simple and effective depth gauge can be made from a strip of wood with a dowel inserted at a 90° angle; dowel should fit tightly but still be movable.

Reverse Mount

- Cut mandrel to hold and drive vessel by rim. Cut sides parallel or with extremely slight taper using detail gouge, parting tool, or skew. Fit vessel to mandrel. **Do Not Force.** Bring up tailstock and center. For vessels with an uneven rim or uneven upper profile, you can make an overlaying carrier friction chuck using a foam pad and roughed out bowl to hold and protect the upper part of the vessel. Alternatively, you could make a spindle to hold the bottom of the hollow vessel between centers.
- Cut away rebate and refine design at the base or foot for vessel, being mindful of maximum depth or vessel. **This is the final critical design phase.** In the rush to be done, it is all too easy to ignore this final refinement. The goal is to achieve a smooth, perfect transition from the already sanded lower half of the vessel to the final completed profile of the lower half of the vessel. If there is an uneven transition, you will see it when the vessel is done. Even if an uneven transition is not readily visible, it will be identified by tactile examination...you can feel it before you can see it. Final cuts should be made with a bevel rubbing cut and finished with a shear scraping cut. The bevel rubbing cut may require a bowl gouge with a less acute bevel angle than your standard bowl gouge. When the shape is done, shear scrape and sand freshly cut areas to blend in with rest of form. Leave a center support at the live center contact area for sanding. Any turned design elements on the bottom of the vessel can be added now. After sanding, you can reduce thickness of the support, and then carve and/or sand it off. This is done off of the lathe.
- My goal is sand a green wood vessel to 320 grit at this time. This stage is done at 200 rpm to avoid excess heat buildup which can lead to excessive checking. I alternate power sanding and hand sanding with successive grits. This is so I can be sure of removing the sanding marks from the preceding grit (i.e., swirled vs concentric).
- If you are turning green wood, allow the piece to air dry. You can measure this with a digital kitchen scale to monitor moisture loss. When dry, recheck the vessel between centers and sand starting at 320 grit to 600 or 800 grit. I will do this at around 100 – 150 rpm.
- Complete the project with the finish of your choice. I use 3 coats of a wipe on polyurethane and then apply and hand buff a paste wax.

VERY SMALL HOLLOW FORMS

Why turn very small hollow forms?

- Builds fine motor skills without investing much in time or materials.
- Good use for cut-offs scraps, and special small pieces of wood.
- Miniatures are cool!

Wood selection and orientation

Almost all of my very small hollow forms are turned end-grain, that is, the grain is parallel to the bed of the lathe. End grain is preferred because we want the blank to be securely gripped by a 4-jawed chuck. Any wood that can be securely gripped by one end should be suitable. This includes most hardwoods. Generally hardwoods with straight tight grain are best. Denser woods are better because they take fine detail and are not prone to splitting. Some good local hardwoods include pecan, mesquite, elm, mulberry, walnut, white oak, and crepe myrtle. Many exotic hardwoods are also very good for turning very small vessels. Some of my favorites are blackwood, cocobolo, rosewood and bocote. Because the scale of these projects is so small, it's best to avoid soft woods and soft hardwoods, as they do not take fine detail, and do not have the structural integrity to maintain their form when turned very thin. Spalted woods are OK as long as they are only discolored. Once a wood becomes more than slightly spalted, it becomes weaker, and eventually is too punky to turn. Small differences in the wood's strength become important when spindles and wall thicknesses are measured in millimeters. Most burls are not a good choice for small hollow vessels because the structural integrity of straight grain is required to keep the item being turned from snapping off. If the grain is oblique or sideways, the zone of weakness is not optimally oriented, and the item will snap off with the least bit of friction (like when sanding).

Tools and techniques

Turning a miniature vessel offers some new lessons in design, skills, and tool construction. So, what size qualifies for miniature? Let's just say less than a few inches. Turning very small hollow vessels offers an opportunity to learn additional fine-scale eye hand skills while working with small pieces of wood. Often the difference between a good shape and a great shape is measured in millimeters (or less). There is not much invested in time or wood, so you can play...try out different forms, and maybe only complete the ones you like. This is a good opportunity to experiment with different designs. Along the way you will also refine your fine tool control skills as you learn to execute the designs you have in mind. Emulating vessel shapes by others is another good way to learn and also learn what you like. There is more leeway for wood selection here. An interesting blank that is not suitable for turning a finial might be ideal for a miniature vessel. Convolute grain and spalted patterns can add interest to small decorative pieces as long as they do not compromise the blank's structural integrity. Also, I usually avoid using wood that has widely spaced growth rings because the grain seems out of scale with the size of the piece.

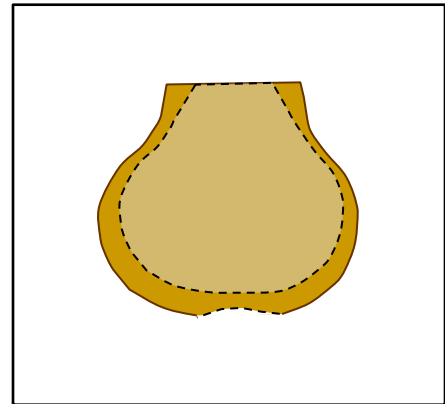

One thing that I like about making the miniature vessels is that there are few tools on the market for hollowing out these items. Fortunately, an inexpensive tool kit can be assembled from scraps of metal and wood that are usually lying around in hidden corners of the shop. To the right is a sketch or a mini scraper can be made from drill rod. For this tool, make a handle and glue in a 4" long piece of 1/8" drill rod. The upper face of the scraper is formed by laying the end of the tool on a 5" or 6" grinder wheel to get a slightly hollow ground oval shaped surface that is 2-3 times longer than it is wide. Then run a curved bevel around the front of the tool edge. The angle between the long face and the bevel could be around 70° – 80°. No need to measure...just make the angle less than 90°.

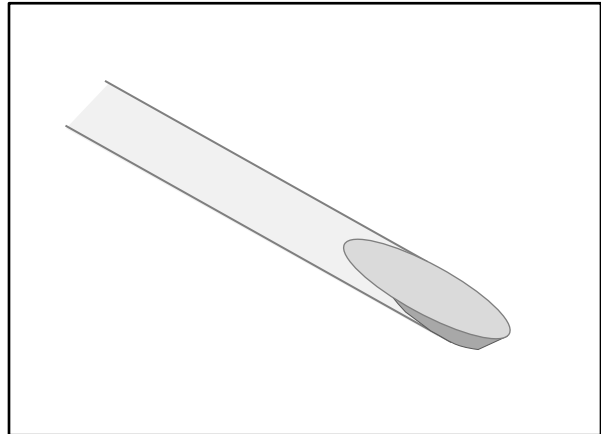

The most useful and versatile tool making stock for mini hollow vessel tools is from spade drill bits. These are flat bits designed to drill quick holes in rough carpentry **(A)**. The flat end of the bit allows great versatility in the types of tools that can be made. The three basic shapes I use are an oval shape with a rounded end, **(B)**; an offset cutter with a 45° angle **(C)** and an offset cutter with an 80° angle **(D)**. These tools are not difficult to make, but the process does involve a bit of time at the grinder. Select bit stock that is wide enough to accomplish the shape, but without much left over metal to be ground away. First, establish the desired outline. It may help to draw your shape on the spade bit with a marker. These tools are scrapers, so the end of the tool will need to be sharpened. As in the previously described tools,

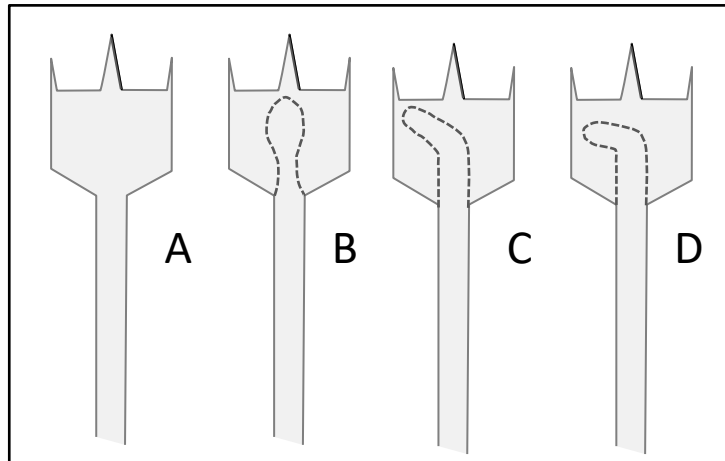

the exact angle between the top face and the bevel could be around 70°. It just needs to be sharp enough to hollow the mini vessel, and should also be easy to sharpen. The oval shaped tool is sharpened on the front and front part of the sides. The offset tools are sharpened around the front and front part of the sides, and the left side. This makes it easy to make a push cut or a pull cut while hollowing. Because these tools are small, and take some effort to shape, they should only be retouched with a diamond stone rather than going back to the grinder. A few passes on the bevel should restore a sharp cutting edge.

Once you start making mini hollow vessels, you may find some additional tools are helpful. Here is a list of some other items in my mini-hollowing kit.

- Small calipers are useful to estimate wall thickness. Small figure-8 calipers would be useful but seem to not be on the market. A wire caliper made from thin gauge steel works well too.
- Small flashlight

- Flexible straw or vinyl tube is used to blow shavings out of the vessel.
- Depth gauge, small dowel and pencil, or something fancier.
- Mini skew or other pointy tool.
- Small “U” shaped carving gouge
- A box to keep it all organized. I repurposed an old cigar box.

Turn a miniature hollow vessel in six stages

1. Start with the spindle blank mounted in the chuck. Rough out a cylinder and make a fresh cut across the grain at the end of the blank. This is to ensure that the rim will have a clean cut across the fragile end grain while it is still well supported. Shaping the outside of the vessel involves cutting rounded shapes and gentle elongate curves. The $\frac{1}{4}$ " bowl gouge is a good all-purpose tool here, although the $\frac{1}{4}$ " detail gouge is good for refining the lower portion of the form. When shaping the vessel, the aim is to establish most of the profile, while also leaving an approximately $\frac{3}{8}$ " wide stub at the bottom. This should be strong enough to support the form while hollowing and sanding. The form should be mostly shaped, and ready to sand later on.
2. Using a scraper, cut a cylinder down the axis of the vessel. This is primarily to establish the depth and provide an entrée for the offset tools. Cut the cylinder in successively deeper stages, until it is almost at maximum depth. Be sure to measure carefully so that your vessel does not wind up with a hole in the base when you part it off later on.
3. Using the offset scrapers, gradually hollow out more of the vessel, starting below the rim and working both deeper and wider in successive cuts. Take light cuts and measure often. These forms are so small it is all too easy to inadvertently remove too much wood. As shavings accumulate in the vessel, stop and remove the shavings. Use your flexible straw, blowing into the long end.
4. Gently cut the interior to its final thickness, measuring regularly with the calipers. Listen to the wood. You may notice that the pitch of the vibrations of the tool against the wood gets higher as the wall gets thinner. After the wall is at the final thickness, you can smooth out the interior bottom of the vessel. There may be a nub or bump there as it often is difficult to cleanly cut the center of the bottom with the offset scraper. Use the round ended scraper to locate the center of the interior, then lightly push into the wood for a fraction of a millimeter, and then sweep the tool to the left, feathering into the interior wall profile. Be sure to not cut too deep. Once you are done hollowing, take a final cut parallel to the axis of the lathe from the rim to the inside of the vessel. This should leave a straight sided interior profile from the rim to the inside. Now is the time to sand. You should be able to start with 180 or 220 grit sandpaper. Proceed through progressively finer grits, ending at 600 or 800 grit.

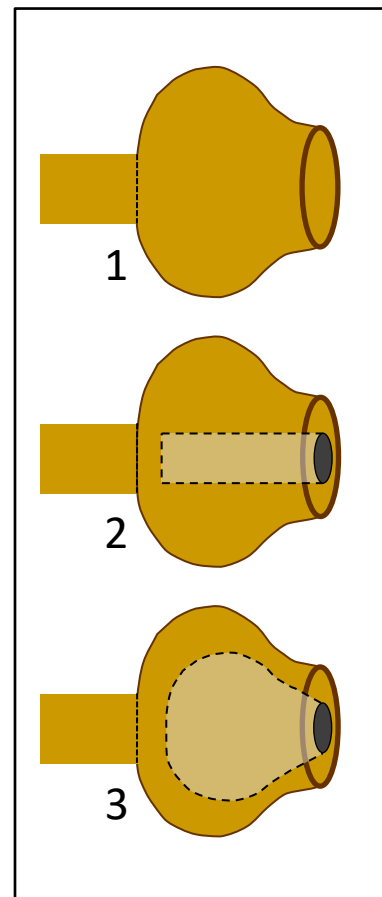

5. First, make a few shallow cuts with the parting tool, leaving enough wood to support the vessel during some light finish sanding on the base. The idea with parting is to cut a clean surface that requires little if any sanding. At times like this, a super thin super sharp parting tool is called for. Make the first few cuts perpendicular to the axis of the lathe so that the base of the vessel is flat. Sand the lower portion of the vessel wall if needed. Now it is time to part the rest of the way across the stub. Start the cut about $\frac{3}{16}$ " in from the outer edge of the perpendicular cut just made. Angle the cut about 15° right of perpendicular, cutting a shallow cove in the bottom of the vessel. Do not cut all the way through as there is a substantial risk of pulling out the short end grain at the bottom of the vessel. Instead, stop short of cutting through and make a final through cut one tool width to the left of the angled cut just made. This will leave a small stub at the base of the vessel. This can be hand sanded, carved away with your small "U" shaped carving gouge, removed with a round Dremel burr...or proceed to step 6 and reverse-chuck the vessel.

6. The final step is to cut the part of the stub remaining in the chuck to form a mandrel for reverse chucking the vessel. Cut a straight sided mandrel that allows you to firmly fit the aperture of the vessel over the mandrel. The intent is to hold the piece firmly enough to be able to turn and sand the base of the vessel, but without splitting the vessel in two. Sadly, this is all too easy to mess up. Take your time and be careful. Having cut parallel sides on the inside of the aperture in step 4 makes reverse chucking a lower risk endeavor. If you cut the mandrel too thin, a bit of tissue or paper towel may take up the extra space. Once chucked, support the spinning vessel with one hand while turning the nub away with the tip of the detail gouge. Sand the recess of the base at this point, being careful to preserve the flat base of the vessel. Reverse chucking is the only way to ornament the base of the vessel. Use the point of the skew or another pointy tool to cut a few shallow grooves in the base of the vessel. Then lightly sand the bottom with 600 grit sandpaper. The miniature vessel is now ready to be finished.

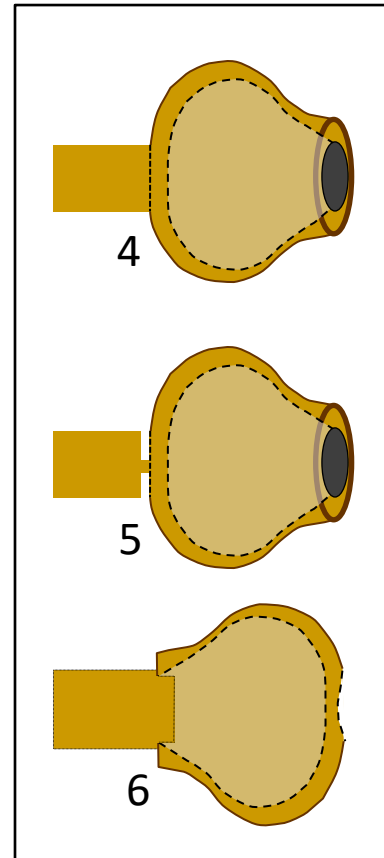

Some final thoughts on hollowing miniature vessels

To paraphrase David Ellsworth, the father of turning hollow vessels ...*You can't turn the inside of a vessel and see what you are doing at the same time.* To be effective, you will have to learn to visualize where the cutting edge of the tool is inside of the vessel, and think about what it is doing. I focus on cutting an inside profile that closely matches the exterior profile. This can be a bit of a Zen moment, making the essentially un-viewable inside of a vessel the best that it can be, just for the sheer pursuit of perfection.

Finally, and I can't say this enough, there is no substitute for time spent at the lathe, working on problems and finding solutions. The only way to get better is to practice, practice, practice!

ABOUT THE ARTISTS

ROY ALVAREZ

Katy, Texas

Phone: 281-799-1800

Email: raheirlooms@gmail.com

Kirk DeHeer and I were having a discussion of the woodturning community and we both find that for the most part we work alone and mostly in obscurity; however, we enjoy coming together to have open discussions about the craft. We are a tight knit global community of individuals who enjoy sharing our discoveries, creations and experiences as well as being a giving community of principled individuals. As a member of Gulf Coast Woodturners Association in the greater Houston area, I am blessed to be a small part of a very diversified group of turners who have great reverence for the turned form. Whether a beginning turner or a world-renowned expert turner, we all hold a great respect for everyone's turning journey and contributions to the craft. I hope that my presentation: Creating a Woodturning Skill Set will reflect this value of sharing in the best interest of the craft.

[<Link to List of Demonstrations>](#)

No
Photo
Available

SAM ANGELO

1092 South Ponderosa Lane

Worland, Wyoming 82401

Phone: 307-431-5395

Email: samandcheryle@gmail.com

Website: www.wyomingwoodturner.com and www.samangelo.com

ETSY shop: <http://tinyurl.com/y6e3v4da>

YouTube Channel: <https://goo.gl/xR39S5> (wyomingwoodturner)



Sam Angelo grew up in Akron, Ohio. After high school graduation in 1968, he attended college at Eastern Montana College in Billings - receiving a BS in 1972 and a M.Ed. in 1985. In 1974, he met and married his wife Cheryle. The next 40 years were spent teaching, coaching, and working as a school counselor. Sam retired from public education in 2011.

Never far from a love of woodworking, Sam began exploring woodturning in 1988. He operated a woodworking shop specializing in making cabinets and furniture. Making and repairing chair parts and table legs established a foundation for woodturning.

Sam has been chasing threads by hand for 10 years. He is drawn to incorporating threads in puzzles, boxes, hollow forms and urn. He teaches thread chasing using traditional British tools and methods. He has produced in excess of 500 YouTube videos on all aspects of woodturning. Sam continues to turn daily, write, teach, and demonstrate. Examples of Sam's work can be seen on this website:

[<Link to List of Demonstrations>](#)

SALLY AULT

San Diego, California

Phone: 619-415-5308

Email: Sallyault@cox.net

No
Photo
Available

Born and raised in San Diego, California, Sally graduated with a BA degree in Art with a Crafts emphasis from San Diego State. Her work there was focused on Weaving, Jewelry Design and Ceramics. During a furniture class, she discovered woodturning. After a break of a number of years, Sally resumed woodturning in 2004.

Sally enjoys all types of wood turning but currently her focus is on lidded containers including the sea Urchin series, open bowls, embellished pieces and jewelry.

Sally's work is shown in the Dunn Gallery in Hawaii, Hawaii, The Real Mother Goose in Portland, Oregon, The gift shop at Anderson Ranch Arts Center in Snowmass, Colorado, at The A Store in Albuquerque, New Mexico and in the gallery at Studio 38 in Spanish Village Art Center in Balboa Park, San Diego. She has won several prizes since 2010, including her Sea Urchin Box which won a special purchase award at the 2012 Small Image Show at Spanish Village.

[<Link to List of Demonstrations>](#)

ELI AVISERA

Jerusalem

Phone:

Email: jaburt999@aol.com



Eli Avisera was born in 1960 and grew up, studied, and lives in Jerusalem. Between the years 1973 - 1977, he studied at the School of Wood Art in Jerusalem. Since then, Eli has been a professional woodworker. Eli is an international woodturning demonstrator and teacher. During the last 20 years, he has taught his craft in France, Germany, Italy, Canada, Japan, the United Kingdom, Australia, China, Nepal and over 25 different states in America.

Eli uses a line of his own signature tools created by Ashely Iles Tools. Eli used his decades of experience to design this M2 high-speed steel line that features his most celebrated innovation, the double-bevel for the gauge and convex bevel for the chisel. In 1988, Eli established the "Wood Craft Center". There, hundreds of students at all levels have learned woodturning, building furniture, wood carving and realistic sculpture, and violin-making. Students from teenagers to pensioners from Israel and abroad come to learn new skills.

Eli is one of the world's leading wood art masters. His creations are exhibited in many locations around the world.

[<Link to List of Demonstrations>](#)

DONNA BANFIELD

Derry, New Hampshire

Phone: 978-618-7192

Email: donna@livealifelessordinary.com

Website: www.livealifelessordinary.com>

Donna Zils Banfield had been creating works of art in wood since she received her first lathe as a surprise Christmas gift from her husband in 2001. Donna's skills on the lathe were self-taught, but honed through workshops taught by gifted and skilled artists and turners who shared their knowledge. Her carving techniques and designs evolved after studying under several internationally recognized fine art and craft masters.



A teacher of woodturning since 2007 at Rockler Woodworking and Woodcraft, she now offers private one-on-one instruction in her studio in Derry, NH. She has shared her knowledge and techniques with woodturning clubs throughout New England and beyond and has demonstrated for regional and international symposiums since 2008.

She has written articles for the Journal of the Guild of New Hampshire Woodworkers and the AAW's Woodturning FUNdamentals. Donna has been a juried member of the League of New Hampshire Craftsmen (LNHC) since 2010 and currently serves as a Juror in wood, evaluating and critiquing applicants seeking admission to the League as a juried craftsperson. Her work can be found in private collections in Australia, India, Taiwan, and across the U.S. For more information, please visit her website.

[<Link to List of Demonstrations>](#)

KEVIN BASSETT

Richardson, Texas

Email: kevin@kbwoodturnings.com

Website: www.kbwoodturnings.com

Mr. Bassett brings to his studio years of woodturning experience, a degree in Plant Pathology and over three decades of experience as an award-winning Arborist. His extensive knowledge of rare and common woods serves him well in his studio. Upon seeing a particular wood sample his inspiration is immediate in terms of design and final product. With a lifetime spent trying to preserve trees, which are, according to Mr. Bassett, "the last true witnesses to our history," every wood sample is treated with value and respect. Mr. Bassett's one-of-a-kind turned pieces are individual works of art.

[<Link to List of Demonstrations>](#)

No
Photo
Available

BRIAN BLOHM

Dallas / Fort Worth, Texas

Brian Blohm is a resin casting expert living in the Dallas Fort Worth area with his lovely wife and two dogs. He has an energetic son that he loves exploring the outdoors with as much as possible. Brian has been resin casting and pen making for seven years and has become an expert in both disciplines. He

No
Photo
Available

regularly demonstrates, live streams online, and does lessons on various resin casting techniques using all types of reins. He truly enjoys working with, and developing new methods to create unique and interesting resin casts. He has been instrumental at progressing the hobby and runs several facebook groups where excellent help can be found. The most active group for his resin work is “Pen Blanks Resin Casting”.

[<Link to List of Demonstrations>](#)

ANDY CHEN

College Station, Texas

Email: andychentx@gmail.com

Andrew (Andy) Chen is from College Station, Texas. He is a self-taught wood enthusiast and has been woodworking almost his entire adult life. Early on he built furniture entirely with tight-fitting joinery (without nails and screws). This provided him with the knowledge of cutting wood accurately that is the foundation for the segmented turning that he started in 1992. He is a well-recognized turner and has demonstrated at numerous turning clubs and regional and national symposia and internationally. He has taught at Arrowmont. His woodturnings are in many private collections. His segmented work has been shown in galleries in Kerrville, TX (Kerr Arts and Cultural Center), Houston, TX (Houston Center for Contemporary Craft) and they were represented by Whistle Pik Galleries in Fredericksburg, TX. He was invited to participate in a del Mano Gallery’s exhibition, Piece by Piece, in 2013. His work has also been included in the photo gallery of Ron Hampton’s book: Segmented Turning: A Complete Guide. He is the founder and de facto president of the Brazos Valley Turners in the Bryan/College Station area of Texas since 1998.



[<Link to List of Demonstrations>](#)

BUDDY COMPTON

Colorado City, Texas

Email: bcc@wtconnect.com

Website: www.woodturningsbybuddy.com

I was, for 33 years a public school teacher, coach and administrator. I retired in 2002 and was introduced into woodturning by Larry Roberts in 2004.

I have studied and worked to bring my turning to an acceptable level. My development has always been under the guidance of Larry Roberts, a master turner and my wife Carol who is my greatest asset for design and color combinations. I enjoy the thrill of turning a chunk of wood into a nice, usable one-of-a-kind pieces. Creating natural edge, smooth edge, off-centered, large and small pieces is what I strive for each day. I also enjoy watching the transformation of the wood by using different embellishment methods. I work with different techniques and media which include texturing, airbrushing, paints and dyes, pyrography, and using various inlay materials.



I am currently a member of the Comanche Trail Woodturnings in Midland, Texas, a member of American Association of Woodturners and served as Second Vice President, Vice President and President of SWAT.

[<Link to List of Demonstrations>](#)

REBECCA DEGROOT

Spring, Texas

Phone: 989-287-2352

Email: rebeccaedg@gmail.com

Website: rebeccadegroot.com



Rebecca was born and raised with her three brothers in Michigan. With their woodworking father and stay at home artist mother, she and her brothers have never been short of inspiration. Rebecca and her brothers were homeschooled from an early age, therefore given the opportunity to explore their forty acres and appreciate the nature and wildlife. Throughout her young life, she developed her love of teaching and sharing information with others. She later went on to pursue an education at Kendall College of Art and Design of Ferris State University in Grand Rapids, MI. After six years and an assortment of interesting twists and turns, she gained two bachelor's degrees; one in Art education and the other in Sculpture and Functional Art. Before graduation, she received an offer to teach high school art at a school in Houston, Texas. The summer after graduation, she packed her things and made her way down to Texas to start this new and exciting chapter of her life. While it has been a challenge these past five years, Rebecca has always found time in her busy teaching schedule to create her own art. She now juggles teaching art, demonstrating woodworking and woodturning, and maintaining the regular production of her own gallery work. Eventually, Rebecca would like to focus all of her time on demonstrating and creating her own work, but we will have to wait and see when that dream will be made into a reality.

[<Link to List of Demonstrations>](#)

KURT HERTZOG

Henrietta, New York

Email: kurt@kurthertzog.com

Website: kurthertzog.com

Kurt Hertzog retired after 35+ years as a computer and automotive engineer. He now enjoys being a professional woodturner. With 20 years of turning experience, he enjoys the continuum of woodturning from making his own turning tools to photographing his finished turnings. As a frequent demonstrator and instructor on all facets of woodturning, he particularly enjoys teaching tool sharpening, work holding, ornaments and advanced pen-making.



You can see the range of his work on his website and here: www.penmakersguild.com

[<Link to List of Demonstrations>](#)

CARL JACOBSON

Website: www.thewoodshop.tv

Carl Jacobson started woodworking with his grandfather as a young boy. He continued woodworking through high school and started woodturning after seeing a turned project in a friend's shop. Shortly after YouTube started, he was looking for a "how-to" video for duck calls, but he found no results, so he decided to make his own video. Some of his fondest memories are working with his grandfather in his wood shop. Being able to share our passion for woodworking ties it all together.

[<Link to List of Demonstrations>](#)



LYLE JAMIESON

Traverse City, Michigan

Phone: 231-947-2348

Email: lyle@lylejamieson.com

Website: www.lylejamieson.com

Lyle's trademark is hollow forms. His primary influence came from exploring non-functional turning. He is the inventor/creator of the Jamieson Hollow Form Turning System for safer, in-control hollowing that is fun too. The system creates a rest behind the main tool rest which simplifies the hollowing process. A turner can stand beside the lathe and gently guide the cutter into the vessel with fingertip control. One advantage is the use of a laser beam measuring device to accurately measure wall thickness of hollow forms. This makes hollowing fun and easy, no need to work hard anymore.

[<Link to List of Demonstrations>](#)



MARTY KAMINSKY

Bacliff, Texas

Email: martykaminsky@gmail.com

I began my interest in photography and woodworking while still in elementary school and by the time I was in high school I taught both subjects at the Toledo (Ohio) Central YMCA Youth Department. In 1974 I graduated from The University of Toledo with a Bachelor of Science degree in Electrical Engineering. While a student, in addition to my engineering courses, I took several art courses including sculpture, glass blowing, design, and calligraphy. After college I taught photo courses for The Lima (Ohio) Arts Association.

My engineering career, starting at Ohio's Standard Oil Company led me to Texas in 1980 where I worked for Exxon, Cain Chemical, Occidental Chemical, Contech Engineering, and S&B Engineering. While an engineer I also provided photographic images used in brochures, presentations, and displays.

In late 2000 I saw my first woodturning demonstration. I instantly knew that this art form suited me – within a month I purchased a lathe and started making wood shavings with joyful



abandon. With much mentoring from my friend Bill Berry, and membership in the Gulf Coast Woodturning Association and the American Association of Woodturners I was able to learn my craft much quicker than I would have otherwise (although I still think Bill is holding out vital information from me).

I have exhibited photography, jewelry, and woodturnings in shows at The Lima (Ohio) Arts Association, The Arts Alliance at Clear Lake (Houston, Texas), Innuendo Gallery (Galveston, Texas), San Jacinto College (Houston, Texas), Fleury Gallery (Houston, Texas), the Pearl Fincher Museum of Fine Arts (Spring, Texas), and elsewhere. For several years I taught photography and jewelry/metalsmithing in the art department of San Jacinto College South, and I have taught woodturning and photography at the Gulf Coast Woodturning Association and the Southwest Association of Turners (SWAT) symposiums, as well as demonstrated for various turning clubs and at special events. I've had a one-person show of photographs and woodturnings at the San Jacinto College Marie Flickinger Fine Arts Center Gallery.

I live in Texas with my wife, Martha (who promotes me shamelessly) enjoying a beautiful view of Galveston Bay.

[<Link to List of Demonstrations>](#)

ALAN LACER

River Falls, Wisconsin

Email: alan@alanlacer.com

Website: www.alanlacer.com and www.alanlacer.info

Alan has been involved in woodturning for over forty years as a turner, teacher, writer, exhibition coordinator, demonstrator and expert witness.

Alan has been an instructor and demonstrator, working in all fifty states and six foreign countries. His published writings—upwards of 150—cover a wide spectrum of woodturning from historical and cultural, technical and specific projects. His specialties include the skew chisel, sharpening techniques, finishing, lidded boxes and making/using hook tools. In 1999 he was awarded the Honorary Member Award for that year from the American Association of Woodturners for his contributions to the field. He has appeared on PBS in the series, Woodturning Workshop and on the DIY channel.

[<Link to List of Demonstrations>](#)

PETE MARKEN

Calera, Alabama

Email: p_marken@bellsouth.net

Website: www.petemarkenwoodturning.com

Pete is well known for his precision designs and flawless finishes. Originally from Brooklyn NY, currently living in Calera Alabama about 25 miles south of Birmingham. Pete is retired from the automotive manufacturing industry.

[<Link to List of Demonstrations>](#)

No
Photo
Available



KEN NELSON

Las Vegas, NV

Phone: 702-523-9236

Email: kallenshaan@cox.net

Website: <http://www.kallenshaanwoods.com/>

Born in Vancouver, B.C., Canada, Ken moved to Las Vegas in 1978 where he worked as a musician for 10 years. Always interested in woodworking he transitioned to set design and prop building and landed a job at the Mirage Hotel in the prop department for Siegfried and Roy.



He saw his first wood turned pen at a craft show in 1989 and decided to make a few along with several other craft items. In 1998 Ken moved to the Carpenter shop at the Bellagio hotel and after a few years was introduced to laser engraving as a result of a special project that required a high level of detail. Excited with the results of that project, Ken purchased his own laser engraver in 2002 and started engraving pens for himself and others. In 2003 he created his first laser inlayed pen. It was the Stars and Stripes inlay and after getting an order for 10 kits and painstakingly inserting 50 stars in each pen he decided to make these to sell unassembled as Inlay Pen Kits. Ken named his company Kallenshaan Woods after his two sons Colin and Sean.

After setting up a laser room while at the Bellagio hotel to combine laser engraving and carpentry/woodworking into a variety of projects. Ken left the hotel in 2009 to run his business full time.

He has demonstrated laser engraving and inlay kit assembly techniques at the 2011 St. Paul Symposium and the 2012 Utah Symposium and has been a vendor at SWAT and the AAW Symposiums for the last 10 years.

[<Link to List of Demonstrations>](#)

LARRY RANDOLPH

Springfield, Missouri

Phone: 417-838-1950

Email: MissouriTurner@gmail.com

With a strong background in training and development utilizing modern technologies, Larry has the ability to focus the demonstration process to many skill levels in the audience.

My full time job is video production in which it is not only my job to shoot the video in a stylish and professional way but, to include story telling techniques that draw the viewer in. I've applied these skills to my demonstration planning as well.



[<Link to List of Demonstrations>](#)

BRIAN SCHRADER

Longview, Texas

Email: micbrisch@aol.com

I have been an Engineer in the Satellite Communications industry for more than 30 years. I constantly work with parabolas, ellipses and other conic shapes in my profession. This exposure to unique profiles has carried over into the study of symmetry and form of various geometric shapes.

[<Link to List of Demonstrations>](#)

No
Photo
Available

DREW SHELTON

Georgetown, Texas

Email: dcshelton@gmail.com

I got into woodworking intending to make furniture. I had no interest at all in woodturning. In 2000, a fellow woodworker at my office signed up for a penturning class at Woodcraft and talked me into taking it with him. I was instantly hooked. I bought my first lathe and started cranking out pens. I took a bowl turning class at Woodcraft where there was a last-minute substitute instructor – Gary Roberts. He told the class about the Central Texas Woodturners Association and the AAW, though he did not say he was instrumental in starting both. He had some copies of his book with him, and I bought one. I was astonished to realize who I had just taken a beginning bowl turning class from. I also realized that, in the right hands, the lathe could do far more than I had expected. While I have made a few pieces of furniture since that time, my main focus has been turning. I have held multiple positions within the CTWA, including president.

[<Link to List of Demonstrations>](#)



JIM SWANK

Siloam Springs, Arkansas

Email: james.swank@cox.net

Website: www.underthehill.com

Facebook: UnderTheHillwoodworking

Jim retired after 32+ years as an electrical engineer. He now spends his time as a maker of things. He was first introduced to the lathe in junior high shop class. He spent several years each building cabinets, furniture, refinishing and repairing antiques, carving and doing fretwork on the scroll saw before returning to the lathe about 20 years ago. About 12 years ago, he turned his first pen at a Turn for the Troops event at the Milwaukee Woodcraft store. He has been casting pen blanks for himself and others for the past 8 years, primarily using bottle caps and stamps. The last 3 years, he has been busy making tools for quilters and cooks. You can see the range of his work on his website and Facebook page.

[<Link to List of Demonstrations>](#)



MALCOLM TIBBETTS

South Tahoe, California

Phone: 530-541-6135

Email: malcolm@tahoeturner.com

Website: www.tahoeturner.com

Malcom Tibbetts, of South Tahoe, California, has been a worker of wood since childhood and he has been a segmented woodturning artist since the early 90's. His work resides in many prestigious collections and museums around the world and he has won numerous awards for his art. He shares his passion for this unique art form by conducting demonstrations at national symposiums, woodworking school, and club meetings. As the author of the highly acclaimed book, *The Art of Segmented Woodturning* and as the producer of eight "How To" DVD's. He is recognized as one of the most innovative segmented turners in the world. Examples of his work can be viewed on his website.

[<Link to List of Demonstrations>](#)



BARRY TODD

New Carlisle, Ohio

Phone: 937-543-1762

Email: barotodd@aol.com

Facebook: Barry Todd

My fascination with wood began at an early age as I watched my dad in his shop. I think I've always loved the feel, texture, smell, and story that each piece holds within it. Over the years, I've enjoyed a range of doing flatwork ranging from birdhouses to fine cabinetry. It wasn't until after retirement that I discovered my true passion in life, that being the wonderful world of woodturning. I began by tinkering with an old Craftsman bench top lathe that a friend had given me. I knew absolutely nothing about turning, but managed to make a few candlesticks, ball bats, and some rough bowls while, surprisingly enough, not injuring myself. After about 4 years, someone saw some of my pieces and referred me to a wonderful turner by the name of Jim Burrowes, who became my mentor and good friend until he was diagnosed with dementia and Alzheimer's Disease. In the 4 years since I first set foot in his shop, I now turn full time and am enjoying my second career.

My work has appeared in the *American Woodturner* magazine among other publications. I have appeared on two episodes of the long running PBS series *The American Woodshop*, with Scott Phillips, and the *Woodworking Adventures* series by Woodcraft Stores. My work can be found in private collections in the U.S., Europe, Asia, and the Middle East. I have demonstrated and instructed nationally for the past two years and was recently invited to demonstrate in Australia.

The more I learn about this wonderful art form, the more I realize that I have so much more to learn. My only regret is that I didn't discover woodturning earlier in life!

[<Link to List of Demonstrations>](#)



LARRY ZARRA

Spring, Texas

Email: larryzarra@sbcglobal.net

Larry has been an ardent woodturner for 25 years. In the last 20 years he has participated in numerous juried art festivals, been represented in regional art galleries, conducted demonstrations and workshops in varied venues, and published in the AAW Journal. This is his 6th time as a regional demonstrator at SWAT. During his woodturning career, Larry has created over 1,200 bowls and vessels, and more than 10,000 spin tops. His areas of expertise include; bowls, sculptural vessels, boxes, and a variety of miniature items.

While initially self-taught, he has also participated in master-class woodturning workshops, and taken inspiration from museum collections and published resources. Larry is also a full time geologist who regularly researches, presents, and publishes technical material for professional journals and conferences. When he's not at the lathe, Larry enjoys reading, cooking, gardening, and whitewater rafting.

[<Link to List of Demonstrations>](#)



SOUTHWEST ASSOCIATION OF TURNERS (SWAT) HISTORY

The large regional woodturning symposium known as SWAT has quite a heritage. It got its start in October 1992, when a modest group of Texas turners decided to get together under some large live oak trees near the Colorado River in Columbus, Texas. They couldn't have imagined what they were starting. That was the beginning of what has turned into the second largest woodturning symposium in the world. That gathering became known as Texas Turn or Two, and continued for ten years under that name.

The symposium was conceived and organized by a group of Texas turners who met at the home of Bob Rubel in San Marcos. Among those attending that get-together were Gary Roberts, Clay Foster, James Johnson, Larry Roberts and Mark Potter. That gathering led to the idea that it would be great to have a regional woodturning symposium that could be attended by those who had neither the time nor the money to go to a national event. The four or five AAW chapters then in Texas got to work. The idea at first seemed likely to founder since no one could come up with a site that wasn't too expensive. A few days later, Mark Potter decided that he could move things around in his cabinet shop near Columbus and host it there on Columbus Day. The demonstrators agreed to demonstrate without a charge and the principals decided that if they could get 50 people, they would break even.

On the appointed day, folks began to wind their way down the dirt road a couple of miles outside of Columbus. Soon there were motor homes, trailers, pop-ups and tents scattered all around the area under the big live oak trees. The event was a success! They more than broke even, with approximately 80 attendees. The event returned to Columbus the next year, with John Jordan as the first invited featured demonstrator. By then it had outgrown Mark Potter's shop!

From 1994 through 2000, the Texas Turn or Two symposium was held at Maricopa Ranch RV Park west of New Braunfels, near Canyon Lake. Eventually, attendance became so large that just accommodating everyone at the demonstrations was a major challenge. Add to that a ferocious rainstorm that very nearly swamped the event in 2000, with cold rain blowing in under the demonstration tents and falling into the dining tent and tent where the vendors had their wares to sell, mainly iron.



It became obvious that larger facilities would have to be found, and the event moved to San Angelo for the 2001 Texas Turn or Two. In 2002, the symposium was reorganized as the

SouthWest Association of Turners and held its annual symposium in Wichita Falls. Both the name change and the location were undertaken to make the event more accessible to woodturners from nearby neighboring states. In 2004, the event was moved to Temple in central Texas, to be more accessible to its Texas membership base. The event returned to Wichita Falls in 2005.

The Fifteenth Annual SWAT Symposium, now sponsored by eighteen woodworking clubs in Texas and Oklahoma, was held in Temple in 2006. This was the largest and most successful gathering yet, with some 580 attendees. The large number of attendees and number of demonstration rotations had to be held in two separate buildings. This also pushed the limits that the facility could handle.

The sixteenth annual SWAT Annual Symposium moved back to Wichita Falls, Texas in 2007. Our association now included 22 woodturning clubs in Texas and Oklahoma. The event featured six lead demonstrators and twelve regional demonstrators with a total of 58 demonstrations over the run of the symposium. The symposium was now drawing attendees from Alabama, Arkansas, Arizona, California, Colorado, Florida, Illinois, Kansas, Minnesota, Missouri, Mississippi, Nebraska, Oklahoma, Tennessee, Texas and Washington who came to enjoy the three-day event. That year we ran into space problems in Wichita Falls and need to look into larger facilities.

The Waco Convention Center became the site of the seventeenth symposium in 2008 and has been our home since. The first year in Waco, the attendance was 582 attendees. The symposium offered the largest group of vendors to date, totaling 25. The Instant Gallery was very successful with the added attraction of a Gallery Drawing that was well received. The slate of national leads was the largest number offered in the history of SWAT. The larger convention center allowed growth in attendees and a larger group of vendors. By SWAT's 25th anniversary in 2016, we reached a new record with more than 1,000 attendees and 78 vendors to take care of every woodturner's needs.

Several things make SWAT symposiums attractive. SWAT features world-class demonstrators and an outstanding gallery of art. The registration fee, including lunches, is one of the lowest in the nation. The chef who prepares all of our meals in Waco receives rave reviews from attendees; an annual favorite is the prime rib served at the Saturday evening banquet. There are classes and activities for the spouses and a large number of quality vendors.

Another popular item is our 3-for-1 Raffle. It is one raffle that has three drawings, with the drawn tickets returned to the bin before subsequent drawings. During the Friday opening ceremony, we will be giving away a Midi lathe and an Arrowmont scholarship, including travel expenses. The second drawing, at the Saturday evening banquet, features about 30 quality pieces of work donated by invited turners. The third drawing, after lunch on Sunday, is for tools, wood and equipment, including over \$5,000 worth of tools and grand prizes of 3 Variable Speed Midi lathes and a Robust American Beauty can be won. For the price of one raffle ticket, everyone has a chance of winning any of the three drawings.

New for 2019 is an auction on Saturday evening of art pieces donated by local and national turning artists.