

A better way to sharpen gouges

Sharpening

demystified

By Kirk DeHeer

Quite possibly, you've given up on your grinding jig for producing consistent bevels on your gouges. Here's a reliable method that will get you back to the lathe—with tools you can control.

I've been fortunate enough to meet many of the world's best-known woodturners when they've passed through Provo. Because I'm a self-proclaimed tool freak, I've examined their tools and watched their every move at the lathe.

Most of the turners I've met are freehand sharpeners, as I was when I started assisting them at workshops and demonstrations.

That all changed when Dale Nish asked me to assist him in a beginner's class. Because Dale is a freehand sharpener, he asked me to demonstrate sharpening jigs. And he gave me 30 minutes' notice!

Oh my gosh—that was all new to me. I could quickly see that the bowl gouge would be the hardest tool to sharpen with a jig. So I grabbed my bowl gouge and started to set up the jig.

As I remember, the demonstration went well, but

there were questions from the class. Many of them had tried to follow the instructions that accompanied the jig, but my setup wasn't anything like their instruction sheets recommended.

Adjust your thinking

As I researched sharpening jigs, I realized that the control leg did not set the bevel angle like I thought but adjusted the *angle* of the grind on the gouge wing.

The first major hurdle is that the instructions packaged with the Wolverine jig and similar systems confuse new woodturners and experienced turners alike. The side grind is not the *length* of the wing (how far the grinding extended), as the packaged instructions lead you to believe. Rather, the side grind is the *angle* at which the wing is ground.

Although the great turners have different preferences for the bevel angle, there is one common denominator: The bevel of the tool follows around the side to the wing. Unfortunately, if you follow the directions packaged with the sharpening jigs, the wing angles are much steeper than the nose angle. It's no wonder great instructors direct students away from sharpening jigs.



What goes wrong

I bet this has happened to you: You introduce a straight and extremely steep side grind to the work without any support (steel in contact with wood), and the piece grabs the wing and pulls it into the wood. Almost instantly, the gouge rolls over, allowing the edge to dig deeper into the wood and “Bang!” Another catch. Then you put the tool on the shelf because it’s hard to control.

Don’t quit—there’s a way to get comfortable with grinding your turning tools—and a better way to grind your gouges.

To be sure, freehand grinding is faster. But until you acquire keen grinding skills, the method I’ll outline here will help you reduce the variables at the grinder and help you produce a wing (side grind) that matches the nose.

The process *below* works with all of the popular sharpening jigs I’ve found on the market, including the Wolverine sharpening jig and the Tru-Grind jig.

A proven method

Place the flute of the gouge against your grinding wheel and get the shape (profile) that you want. Remember that a straight edge on your flute is more aggressive than a curved edge (convex), which is less aggressive and easier to control.

Now you’re ready to set the control leg on the tool holder. The farther you move the control leg forward (toward the wheel), the more side grind you remove and the steeper the angle. The farther back you move the control leg (away from the wheel), the less side grind you remove.

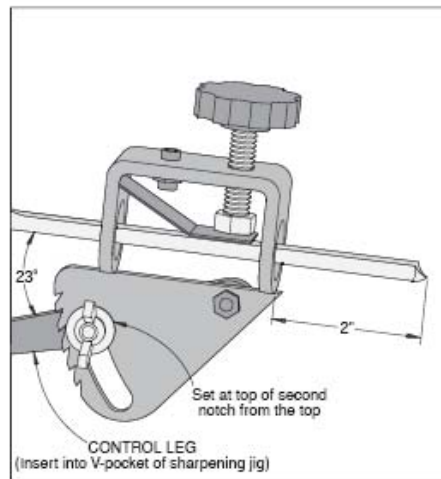

This was the hardest concept for me to grasp and is how most woodturners stray off course with sharpening jigs.

Set the side grind

I believe the control leg should be set at 23 degrees from the bottom of the gouge flute to the top of the second notch on the Wolverine Vari-Grind jig, as shown *above*. You can set this angle and never have to move it again.

Now, slide your gouge into the jig, as shown *above*. To quickly set the jig to 2", use the notch on the Gouge Setup Jig, shown at *right*, or mount a 2" set block on your grinder base.

This 2" setting is key so you can get consistent sharpening. If your control leg and the length of the tool are the same, you’ve set two sides of a triangle. You’re on your way! Now you just need to set the third side (the cutting edge) and sharpen without wasting time or steel.

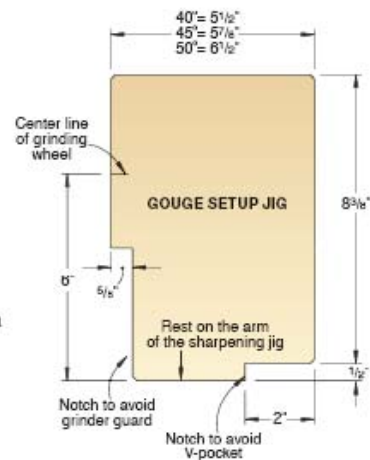

Photos: John Hetherington
Illustrations: Roxanne LeMoine

Set the bevel angle

To set the bevel angle, make a **Gouge Setup Jig** from $\frac{3}{4}$ " plywood, as shown on page 33. Then use this jig to set the V-arm at the proper distance from the wheel (6" from the V-pocket to the centerline of the wheel), as shown in **Photo 1**. You may have to elevate your grinder. You can rely on this jig regardless of the size of your gouge or the diameter of your grinding wheel.

The setup jig quickly locks your grinding into a consistent bevel angle. You may wish to make three of these jigs—one each for 40, 45, and 50 degrees (40 degrees is the most aggressive; 50 degrees gives you the most control).

Now, place the control leg in the V-pocket, as shown in **Photo 2**. Start grinding one wing, then pull the tool away from the wheel and grind the other wing. Finally, blend the wings with the nose.

In the turning classes I teach in Provo, I recommend a 50-degree angle as the best starting point for tool control, as shown in **Photo 3**. If you get confused about sharpening angles, think of 90 degrees as no sharpened angle and a really steep angle as 30 degrees. A metal protractor like the General model shown at *right* sells for about \$11. It's a good investment.

Common mistakes

- **Not setting up the jig the same way each time.** The quicker you learn to produce a consistent grind, the faster you'll advance your skills. This method will get you back to the lathe quickly.
- **Over-grinding the nose of the tool.** Most new turners start grinding at the nose of the tool, then grind one wing, hit the nose again,

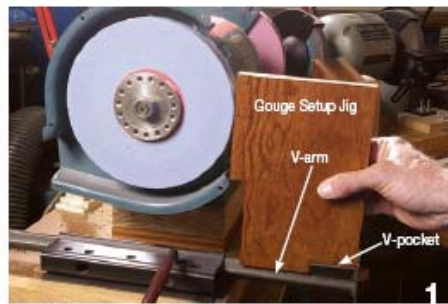

The Gouge Setup Jig will help you set the V-pocket at the proper distance from the grinding wheel for consistent bevels.



For best control of sharpening, hold the Vari-Grind in your hand. Avoid attempting to control by gripping the tool handle.



An inexpensive metal protractor will help you measure your tool bevels.

grind the other wing, and finally return to the nose. This means you spend too much time on the nose and end up changing the profile. Don't do that! Follow the step-by-step instructions *above*.

- **Grinding in one sweep.** When you do this, you have a tendency to hesitate as you transition from the wing to the nose and from the nose to the wing. This causes a bird-beak grind, which is challeng-

ing to control.

- **Failure to keep the tool moving.** You will create flat or straight spots if you over-grind in one area.
- **Gripping the tool handle.** For better control, grip the tool at the grinding jig when you sharpen, as shown in **Photo 2**.

Kirk DeHeer (kdeheer@cs.com) lives in Provo, Utah. He is a full-time woodturner and demonstrator.